

INTEG **M** HYBRID INVERTER

M2HT-25/29.9/30/40/50K-150



User Manual

ENGLISH VERSION



CONTENTS

1	About This Manual.....	5
	1.1 Purpose	5
	1.2 How to Use This Manual.....	5
	1.3 Target Groups.....	5
	1.4 Symbols.....	5
	1.5 Revision Record.....	6
2	Safety Instructions.....	7
	2.1 Statement.....	7
	2.2 Personnel Safety	7
	2.3 General Safety Statements	8
3	Product Description	9
	3.1 System Overview	9
	3.2 Topology Diagram.....	10
	3.3 Appearance.....	11
	3.4 Symbols on the Inverter.....	12
	3.5 Operation Modes.....	13
	3.6 Back-up/Off-grid Statement	19
	3.7 Power Derating Statement	20
4	Unpacking and Storage.....	21
	4.1 Packing List.....	21
	4.2 Storage Considerations.....	22
5	Installation	23
	5.1 Location	23
	5.2 Installation Tools & Materials	25
	5.3 Mounting the Inverter.....	26
	5.4 External Ground Connection	27
6	Electrical Connection.....	28
	6.1 Safety Instructions	28
	6.2 Electrical Wiring Diagram.....	30
	6.3 Preparation of Wiring Tools and Materials	37
	6.4 AC Connection.....	37
	6.5 PV String Connection.....	44
	6.6 Battery Connection.....	48
	6.7 Meter and CT Connection.....	52

CONTENTS

6.8 Communication Module Connection.....	56
6.9 Communication Connection.....	56

7 Commissioning72

7.1 App Preparation.....	72
7.2 Inspection Before Commissioning.....	72
7.3 Commissioning Procedure.....	72
7.4 Stop the Inverter.....	73

8 Operation74

8.1 Indicator.....	74
8.2 OLED display.....	75
8.3 Button.....	75
8.4 Screen Menu.....	76
8.5 Auto Test.....	88
8.6 Reactive Power.....	90
8.7 Active Power.....	92
8.8 Check Firmware Version.....	93
8.9 Grid Parameter.....	93
8.10 DI Ctrl.....	97

9 Monitoring98

9.1 Communication Module.....	98
9.2 Cloud Monitoring.....	98

10 Troubleshooting99

10.1 Status Code in Waiting.....	99
10.2 Error Message and Solution.....	100

11 Operation and Maintenance 104

11.1 Inverter Maintenance.....	104
11.2 Battery Maintenance.....	105
11.3 Earth Fault Alarm.....	105

12 Common Questions 106

13 Appendix 107

13.1 Technical Parameters.....	107
13.2 Contact Information.....	111

1 About This Manual

1.1 Purpose

This manual is an integral part of Solinteg M2HT-25~50K series three-phase high-voltage hybrid inverters (hereinafter referred to as the inverter). It mainly introduces the assembly, installation, electrical connection, debugging, maintenance and troubleshooting of the products. Please read this instruction carefully before installation.

The products, services or features purchased are subject to the commercial contracts and terms of Solinteg. All or part of the products, services or features described in this document may not be within the scope of purchase. This document serves only as a guide to use, and all statements, information and recommendations in this document do not constitute any express or implied guarantee.

1.2 How to Use This Manual

Before installing and using inverters, please read this manual carefully, understand the safety information and be familiar with the functions and characteristics of inverters. The manual content of subsequent versions of the inverter may be subject to change. The latest manual can be found at www.solinteg.com.

1.3 Target Groups

This manual is applicable to electrical installers with professional qualifications and end-users, who should have the following skills:

- ① Training for installation and commissioning of the electrical system, as well as dealing with hazards.
- ② Knowledge of the manual and other related documents.
- ③ Knowledge of the local regulations and directives.
- ④ Knowledge of the contents of this manual.
- ⑤ Only personnel who meet the above requirements are authorized to perform installation, maintenance, and troubleshooting. Unauthorized personnel do not operate the equipment.

1.4 Symbols

This manual contains important safety and operation instructions that must be accurately understood and followed during the installation and maintenance of the equipment. To ensure accurate use of this manual, please note the following symbol explanations.



Indicates a hazard with a high level of risk that, if not avoided, will result in death or serious injury.



Indicates a hazard with a medium level of risk that, if not avoided, could result in death or serious injury.



Indicates a hazard with a low level of risk that, if not avoided, could result in minor or moderate injury.



Provides extra info to help users use the equipment better. "NOTE" is not a safety warning and does not involve personal, equipment, or environmental hazard information.

1.5 Revision Record

M2HT-25~50K-UM-EN-V01

2024/9/23 First Release

2 Safety Instructions

2.1 Statement

Please read this manual carefully before transporting, storing, installing, operating, using and maintaining the equipment, adhere to safety cautions in this manual and equipment.

Solinteg. has the right not to undertake quality assurance in any of the following circumstances:

- ① Damages caused by improper transportation.
- ② Damages caused by incorrect storage, installation or use.
- ③ Damages caused by installation and use of equipment by non-professionals or untrained personnel.
- ④ Damages caused by failure to comply with the instructions and safety warnings in this document.
- ⑤ Damages of running in an environment that does not meet the requirements stated in this document.
- ⑥ Damages caused by operation beyond the parameters specified in applicable technical specifications.
- ⑦ Damages caused by unauthorized disassembly, alteration of products or modification of software codes.
- ⑧ Damages caused by unauthorized opening of the equipment's cover and disassembling or replacing internal components.
- ⑨ Damages caused by abnormal natural environment (force majeure, such as lightning, earthquake, fire, storm, etc.).
- ⑩ Any damages caused by the process of installation and operation which don't follow the local standards and regulations.
- ⑪ Products beyond the warranty period.

2.2 Personnel Safety

- ① Installers must undergo professional training or obtain electrical-related professional qualification certificates.
- ② Do not wear watches, bracelets, rings, necklaces, and other conductive objects during installation and operation, to avoid electric shock and burns.
- ③ Do not operate with electricity during the installation. When removing or installing cables, sparks and arcs generated by live-line operation can cause fire or personal injury.
- ④ Installers must wear professional protective devices during installation and operation of the equipment.

- ⑤ Do not touch the equipment during the operation since the temperature of some parts of the equipment may exceed 60°C . Touch after the equipment cooling down.
- ⑥ Install the equipment out of reach of children and small animals.

2.3 General Safety Statements

- ① Please strictly follow the content of the manual for proper operation.
- ② Please strictly comply with local regulations for electrical connections.
- ③ Please disconnect the electricity while installing the equipment. Live-line operation is prohibited.
- ④ Please ground the equipment prior to installation. When removing the equipment, detach the grounding protective wire as the final step.
- ⑤ Please select proper cable size according to the local regulation and requirements from this manual.
- ⑥ During the installation of the device, ensure that the cables are firmly connected and the screws are tightened properly.
- ⑦ Any cable damages must be replaced by a professional to avoid risks.
- ⑧ Please disconnect the power source before connection of power or communication cables. Live-line operation is strictly prohibited.
- ⑨ Do not open the front cover of the equipment during installation. Unauthorized opening of the cover and replacement of internal components may result in personal injury, damage to the inverter, and voiding of the warranty.
- ⑩ Do not connect lithium battery terminals without advance turning off the circuit breaker or main power switch to avoid personal injury due to high voltage.

3 Product Description

The Solinteg M2HT-25~50K series inverter is also known as three-phase hybrid inverter or three-phase storage inverter, which is mainly used to combine the PV array, lithium battery, loads and power grid to realize intelligent power management and dispatching.

The M2HT-25~50K series hybrid inverter includes 5 models which are listed below: M2HT-25K-150, M2HT-29.9K-150, M2HT-30K-150, M2HT-40K-150, M2HT-50K-150.

3.1 System Overview

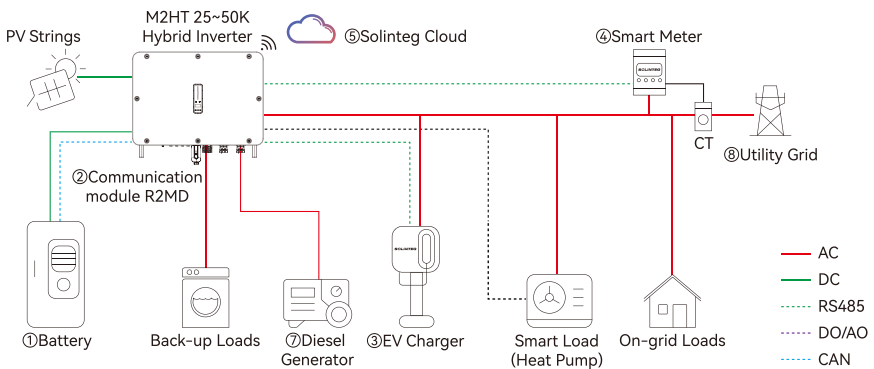

- ① Ensure use of high-voltage lithium iron phosphate (LFP) batteries that have been pre-matched. For details on the compatibility list, please contact Solinteg service team.
- ② The communication module should be the Solinteg R2MD module. The communication module is shipped with the device.
- ③ The EV charger should be the Solinteg ECA series if control is required. For details on specific models, please contact Solinteg service team.
- ④ The meter should be the Solinteg RMM smart meter. The smart meter is shipped with the device.
- ⑤ Solinteg monitoring platform (<https://portal.solinteg-cloud.com/login>).
- ⑦ External diesel generator. For more details on diesel generator solutions, please contact the Solinteg service team.
- ⑧ The applicable grid types for the Solinteg M2HT-25~50K series are TN-S, TN-C, TN-C-S and TT. When applied to the TT grid, the voltage of N to PE suggests less than 30V.

Applicable grid types:

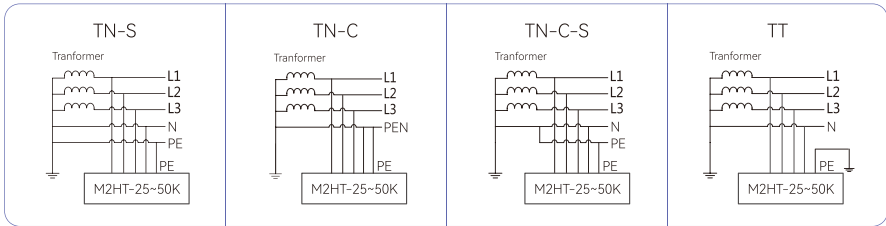



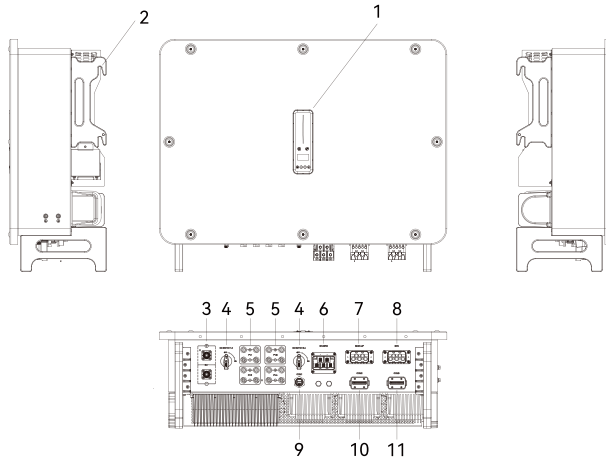







3.3 Appearance



Item	Name	Note
1	Indicator OLED display and button	Display the operation information and working status of the inverter
2	Hanger	Used to hang the inverter on the wall-mounting bracket
3	Battery input terminal	Battery connector
4	DC switch	Used to safely disconnect the DC circuit
5	DC input terminal	PV connector
6	On-grid output terminal	Used for On-grid output cable connection
7	Back-up output terminal	Used for Back-up output cable connection
8	Generator input terminal	Used for Diesel Generator AC cable connection
9	COM1 port	Communication module connection port
10	COM2 port	Multi-functional communication connector
11	COM3 port	

3.4 Symbols on the Inverter

Symbol	Description
 <p>Type Approved Safety Regular Production Surveillance www.tuv.com ID: 2000000000</p>	TÜV mark of conformity.
	CE mark, the inverter complies with the requirements of the applicable CE guidelines.
	RCM mark.
	To avoid the potential effects on the environment and human health as a result of the presence of hazardous substances in electrical and electronic equipment, end-users of electrical and electronic equipment should understand the meaning of the crossed-out wheeled bin symbol. Do not dispose of WEEE as unsorted municipal waste and have to collect such WEEE separately.
	Please read the instructions carefully before installation.
	Danger!
	The surface is hot during operation and do not touch.
	Do not touch any internal parts of the inverter within 10 minutes of disconnecting the power, battery and PV input.
	Risk of electric shock!
	Grounding mark.

3.5 Operation Modes

Solinteg M2HT Hybrid inverter has the following six basic operation modes: General Mode, Peak Shifting, Feed-in Mode, Backup Mode, ToU Mode, Off-grid Mode.

Users can set the operation mode through the inverter display menu, monitoring web and monitoring App.

In General Mode, Peak Shifting, Feed-in Mode, Backup Mode and ToU Mode, when the power grid fails, the inverter will automatically switch to Off-grid Mode provided that On/Off-grid switch is turned on, supplying power to Back-up side loads without changing operation mode.

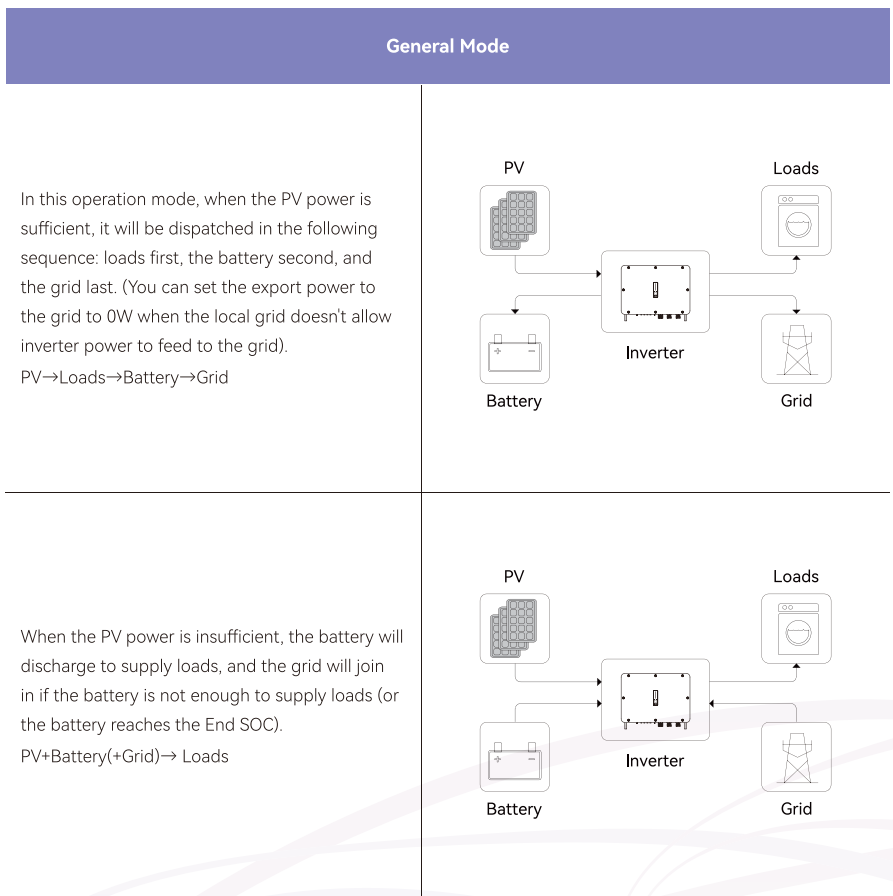

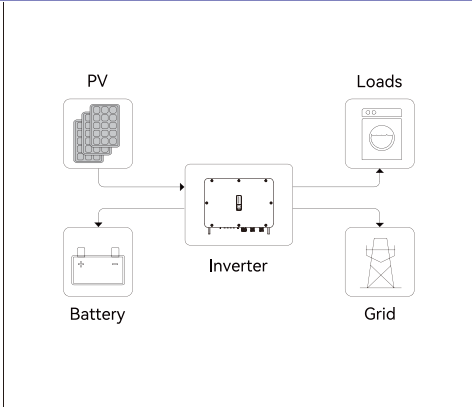

Peak Shifting

EXPmax(kVA): Expected Max. import power from the utility grid.
 PV generation supply priority: PV powers load, battery and utility grid sequentially.

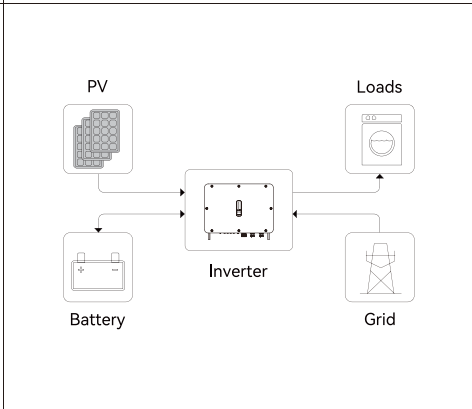

EXPmax(kVA): Expected Max. import power from the utility grid.
 Load consumption priority: PV, utility grid(EXPmax) and battery sequentially.
 Battery will be charged if there is surplus power from PV and/or utility grid.





CAUTION

To realize the "Peak Shifting" function, the load power that exceeded Pmax has to be within the inverter max output power, otherwise, the inverter will only output the max power which allowed.

Feed-in Mode

When the PV power is sufficient, it will be dispatched in the following sequence: loads first, the grid second, and the battery last.

PV→Loads→Grid→Battery

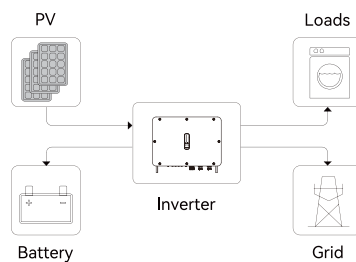

When the PV power is insufficient, the PV and the battery will supply loads together. When the battery power is insufficient (or the battery reaches the End SOC), the grid will join together to supply loads.

PV+Battery(+Grid)→Loads

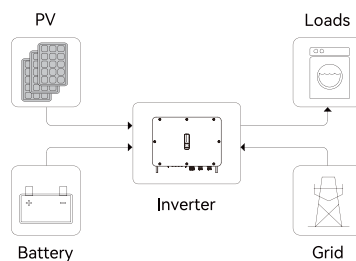

Backup Mode

In this operation mode, the inverter will use power from the PV and the grid to charge the battery until it is fully charged, and any excess power will supply the loads. The battery will not discharge as long as the grid is available.
PV(+Grid)→Battery

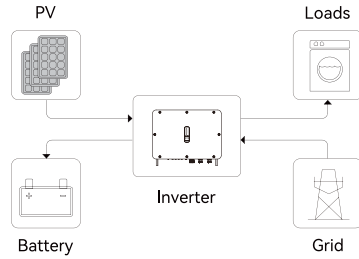

When the grid fails, power from PV and battery will supply loads connected on the back-up side.
PV(+Battery)→Back-up Loads

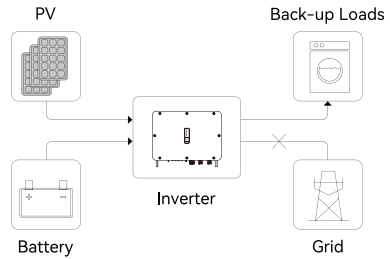

ToU Mode

Users can set different operation modes within a time group. The modes available for setting within a Time of Use (ToU) time group include General Mode, Battery Charge, PV Charging, Peak Shifting, Feed-in Mode, and Battery Discharge.

Among these, General Mode, Peak Shifting, and Feed-in Mode are consistent with the aforementioned working logic.

<p>Battery Charge: This mode allows both the PV and the grid to charge the battery, with the option to set a charging power limit and the end charging SOC.</p>	<p>The diagram shows a central 'Inverter' box. To its left, 'PV (optional)' (represented by solar panels) and 'Battery' (represented by a battery icon) are connected to the inverter. To its right, 'Loads' (represented by a washing machine) and 'Grid' (represented by a power line tower) are connected to the inverter. Arrows indicate power flow from PV and Grid to the Inverter, and from the Inverter to the Battery and Loads.</p>
<p>PV Charging: This mode only allows the PV to charge the battery, with the option to set a charging power limit and the end charging SOC.</p>	<p>The diagram shows a central 'Inverter' box. To its left, 'PV' (represented by solar panels) and 'Battery' (represented by a battery icon) are connected to the inverter. To its right, 'Loads' (represented by a washing machine) and 'Grid' (represented by a power line tower) are connected to the inverter. Arrows indicate power flow from PV to the Inverter, and from the Inverter to the Battery, Loads, and Grid.</p>
<p>Battery Discharge: This mode allows to set a discharging power limit and the end discharging SOC.</p>	<p>The diagram shows a central 'Inverter' box. To its left, 'PV' (represented by solar panels) and 'Battery' (represented by a battery icon) are connected to the inverter. To its right, 'Loads' (represented by a washing machine) and 'Grid' (represented by a power line tower) are connected to the inverter. Arrows indicate power flow from PV and Battery to the Inverter, and from the Inverter to the Loads and Grid.</p>

Off-grid Mode

In the off-grid mode, when the PV power is sufficient, it will supply the back-up loads first and then charge the battery if there's surplus power.

PV→Back-up Loads→Battery

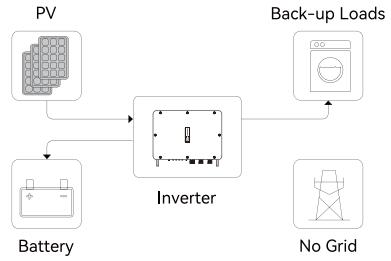

When the power from PV is insufficient, the battery will discharge to supply back-up loads together with PV.

PV+Battery→Back-up Loads

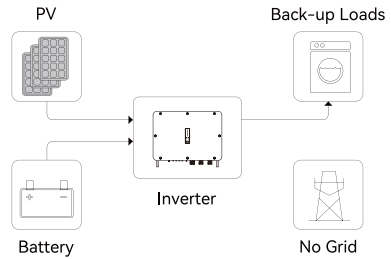

3.6 Back-up/Off-grid Statement

- 

DANGER

The system is not suitable for supplying life-sustaining medical devices, as power outages can be life-threatening.
- 

WARNING

This product cannot be used in medical devices directly related to life.
- 

WARNING

Equipment or precision instruments that may fail or be damaged due to power outages or power fluctuations.
- 

WARNING

Please disconnect breakers on the Back-up and On-grid sides when performing the Back-up inspection and maintenance, to completely isolate the loads and the inverter.
- 

CAUTION

This equipment is prohibited from being used as a traditional UPS.
- 

CAUTION

The Back-up side cannot be directly connected to the grid, otherwise, the Back-up side function will be failure.
- 

CAUTION

The M2HT-25~50K inverter, when operating in Off-grid mode, it will automatically stop the power supply to the Back-up side if there is no available energy from the PV or the battery. Solinteg is not liable for any responsibility for any consequences arising from non-compliance with this instruction.

Generally, the single M2HT-25~50K inverter's On-grid and Off-grid switching time is within 10ms. However, some external factors may cause the inverter to fail in switching to Off-grid operation. Therefore, please check the following precautions for using the Back-up function.

- ① Do not connect loads that rely on a stable power supply for reliable operation.
- ② Do not connect loads with a total power exceeding the back-up output capacity.
- ③ Due to the battery's condition, the current may be limited by various factors such as temperature and weather, among others.

④ When operating in Off-grid mode, the load peak currents and duration should not exceed the inverter's Off-grid operational capability. System stability is affected by both the continuous power of the loads and the inrush current at the time of load start-up. To guarantee the the loads can start and run properly, avoid from starting the following typical devices simultaneously.

Load Characteristic	Load Name	Reason
High inrush current at start-up (Motor loads)	Chainsaws, pumps, among others.	During load start-up, the high inrush current demanded could exceed the inverter's peak current output capacity. Even if the load's power rating is within the inverter's specified Off-grid operational capabilities, successful initiation and functioning are not guaranteed.
Dynamic power	Washing machine, blender, rice cooker, electric oven, among others.	During normal operation, the load power fluctuates repeatedly.
High harmony current	Induction cooker, hair dryer, heat gun, hammer drill, among others.	Non-sinusoidal current may lead to voltage distortion.

Back-up/Off-grid peak output capability

Model	M2HT-25/29.9/30/40/50K-150
Back-up/Off-grid peak output apparent power	1.5 times of rated output power, 10s

The inverter will restart in case of overload protection. The time required for restarting will increase (2 min at most) if overload protection repeats. Try to reduce Back-up load power within maximum limitation or remove the loads which may cause very high start-up current surges.

3.7 Power Derating Statement

Power derating is a method to protect the inverter from overload or other potential factors. Additionally, power derating can also be initiated based on the requirements of the utility power grid.

The scenarios that require inverter power derating include, but are not limited to, the following:

- ① Over-temperature (including ambient and inverter internal temperature): Typically, power derating occurs when the ambient temperature exceeds 45° C.
- ② High altitude.
- ③ Grid over-voltage.
- ④ Grid over-frequency.

4 Unpacking and Storage

4.1 Packing List

The device is thoroughly tested and strictly inspected before delivery. Nonetheless, damage may still occur during shipping. For this reason, please conduct a thorough inspection after receiving the device. Please contact Solinteg or the transport company in case of any damage or incompleteness, and provide photos to facilitate services.

The package of the inverter includes the following accessories. Please check whether the accessories in the packing box are complete when receiving the goods.

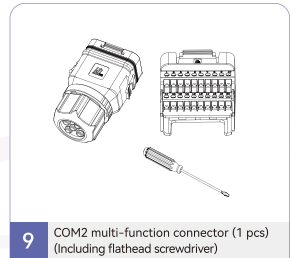
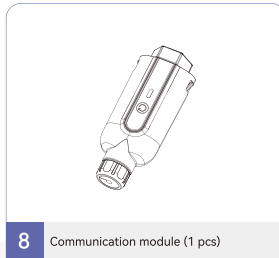
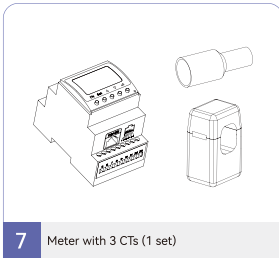
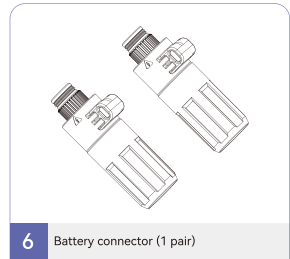
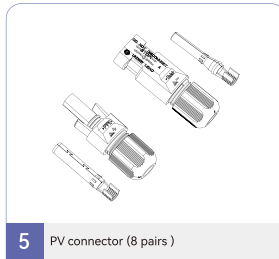
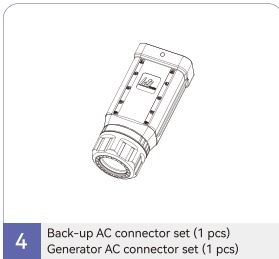
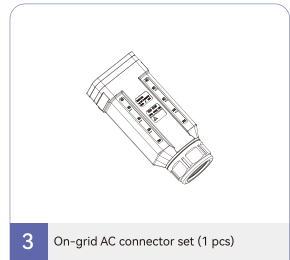
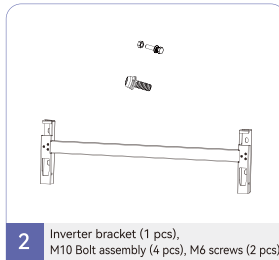
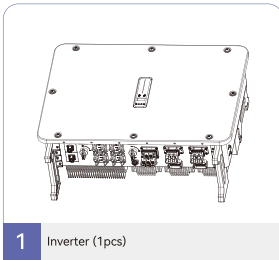

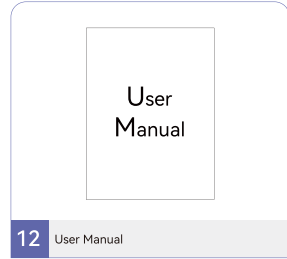
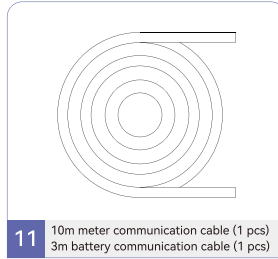
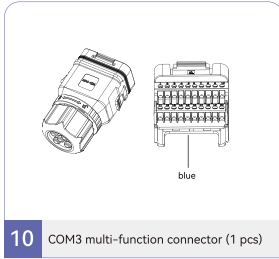

4.2 Storage Considerations

- ① Please store the inverter in the original packages.
- ② Do not expose the inverter to outdoor environments or rain during storage.
- ③ Do not put heavy objects on the inverter.
- ④ Do not pile more than 3 layers when storing a batch of inverters.
- ⑤ Storage temperature: $-30^{\circ}\text{C} \sim +60^{\circ}\text{C}$.
- ⑥ Storage humidity: $< 90\%$.

5 Installation

5.1 Location

- ① The M2HT-25-50K series inverters are designed with IP66 protection enclosure for indoor and outdoor installations.
- ② The inverter must be mounted on a wall capable of bearing its weight.
- ③ Please do not install the inverter on drywall or any other wall with poor sound insulation.
- ④ Install the inverter at eye level for easy inspection of screen data and further maintenance.
- ⑤ The inverter must be installed out of reaching for children.
- ⑥ The inverter should be installed in a well-ventilated environment for good heat dissipation.
- ⑦ The inverter should be installed in a place where the temperature is between -30°C and $+60^{\circ}\text{C}$, and the humidity is between 0% and 100%.
- ⑧ The inverter should be installed in a location that is not over 3000 meters in altitude.
- ⑨ Do not expose the inverter to direct sunlight, nor to rain or snow.

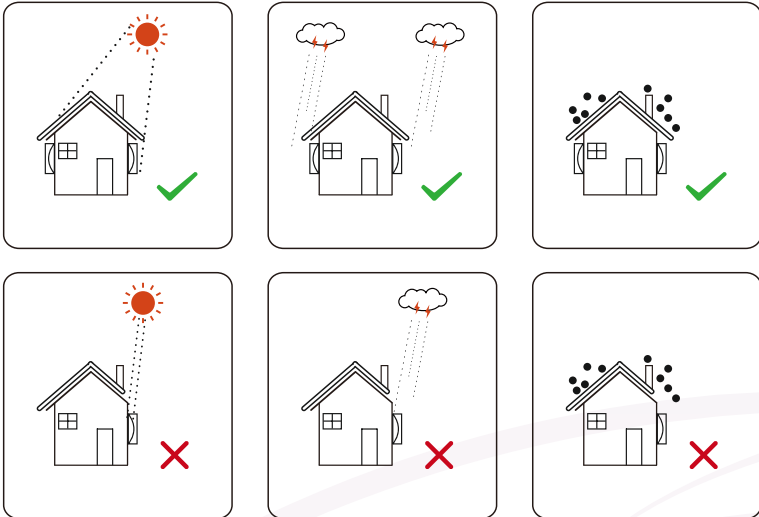

Do not put flammable and explosive articles around the inverter.

▼ 5.1.1 Installation Spacing

Reserve enough clearance around the inverter to ensure sufficient space for heat dissipation.

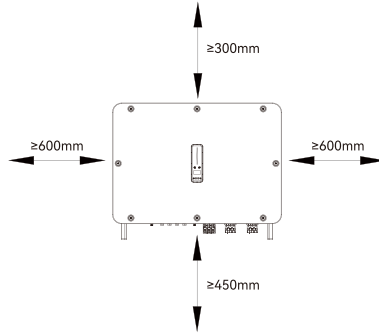

In case of multiple inverters, reserve specific clearance between the inverters.

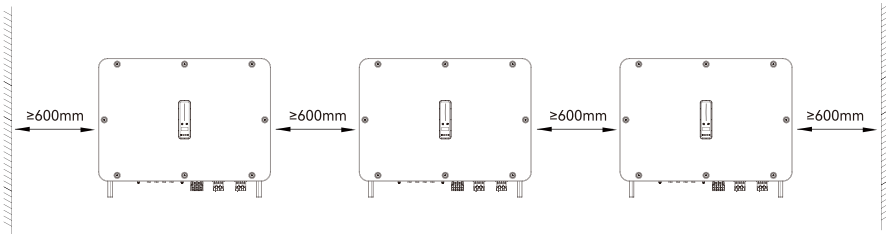

When installing inverters back-to-back, the distance between every two inverters should be at least 600 mm.

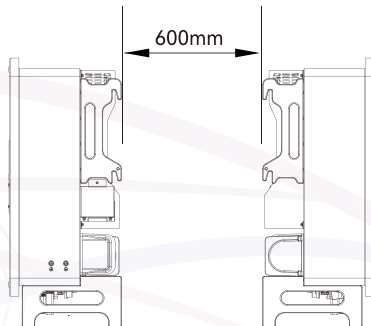

▼ 5.1.2 Installation Angle

Install the inverter vertically. Never install the inverter horizontally, or at forward/backward tilted, or upside down.

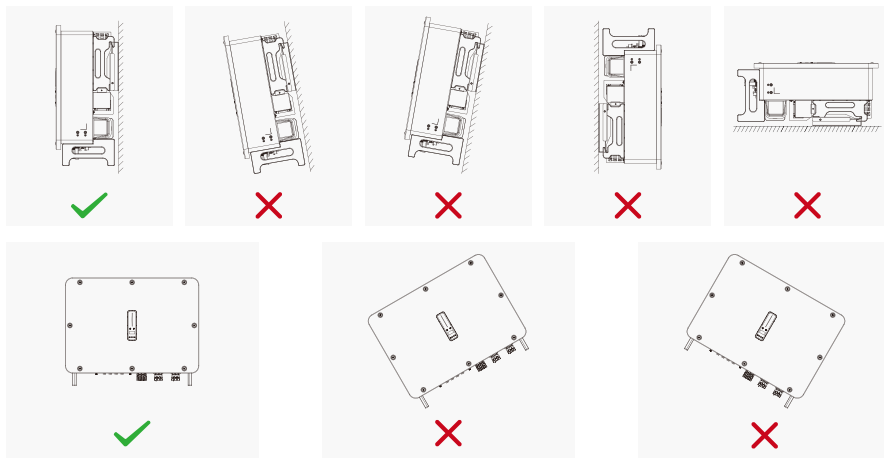

5.2 Installation Tools & Materials

When installing the inverter, please wear professional protective equipment.

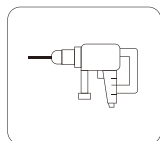

Electric Drill

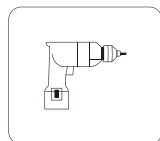

Electric Screw Driver



Hammer

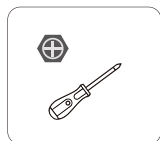

Cross Screw Driver

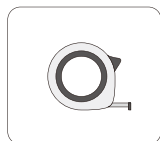

Tape Measure



Mark Pencil

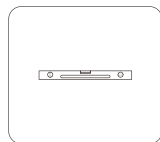

Spirit Level

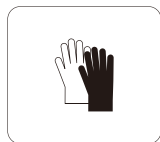

Insulation Gloves



Goggle

5.3 Mounting the Inverter

① Level the assembled inverter bracket by using the level, and mark the positions for drilling holes on the wall. Drill the holes by using a hammer drill.

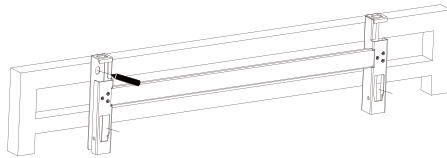

② Secure the inverter-bracket with bolts.



③ Lift the inverter, hang the back rail on the fixed bracket carefully. Secure the inverter with M6 screws.

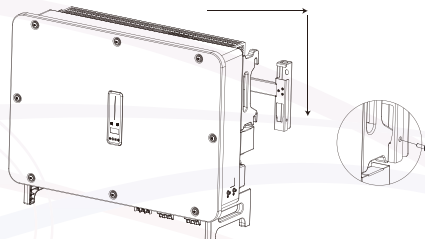

5.4 External Ground Connection

Connect the inverter and ground bar through PE wire to achieve the purpose of grounding protection. Please always remember wiring the PE wire before wiring other wires.

DANGER

Do not connect the N-wire as a protective ground wire to the inverter casing. Otherwise, it may cause electric shock.

CAUTION

Reliable grounding is good for resisting surge voltage shock and improving EMI performance.

For a system with only one inverter, just ground the PE cable.

For a multi-inverter system, all inverters PE wire need to be connected to the same grounding copper bar to ensure equipotential bonding.

CAUTION

According to the French UTE C15-712-1 standard, the inverter's grounding conductor should be connected to the equipotential bonding point via a conductor with a minimum cross-sectional area of 6mm² of copper (Cu) or an equivalent conductor (PE conductor), and it should also be connected to the protective conductor of the AC part.

Ground terminal connection steps:

- ① The external grounding terminal is located at the lower right side of the inverter.
- ② Use a crimping plier to crimp the PE conductor into the OT terminal. Then, use a screwdriver to secure the OT terminal onto the inverter's external grounding bolt. Connect the other end of the PE conductor to the grounding copper bus bar.

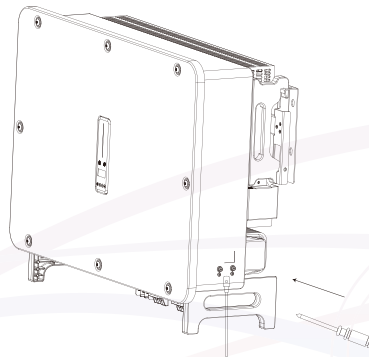

6 Electrical Connection

6.1 Safety Instructions



When installing the inverter, please make sure that both the AC and DC sides of the inverter are completely de-energized to prevent high voltage in the conductive parts of the inverter from causing injury to personnel or damage to equipment.



When exposed to sunlight, the PV array generates dangerous high DC voltage. Please operate according to our instructions, or it will result in danger to life.



The input voltage of the PV string should not exceed the inverter's maximum DC input voltage. Any damage caused by photovoltaic overvoltage is not covered by the warranty.



Do not connect the N-wire as a protective ground wire to the inverter casing. Otherwise, it may cause electric shock.



Do not ground the positive or negative pole of the PV string, otherwise it will cause serious damage to the inverter.



The inverter is not suitable for functional grounded PV arrays as mentioned in the AS/NZS 5033 standard.



Static may cause damage to the electronic components of the inverter. Anti-static measures should be taken during installation and maintenance.



Do not use other brands or other types of terminals other than the terminals in the accessory package. Solinteg has the right to refuse all damages caused by the mixed-use of terminals.



Moisture and dust can damage the inverter, ensure the cable gland is securely tightened during installation. The warranty claim will be invalidated if the inverter is damaged as a result of a poorly connected cable connector.



Please strictly comply with local regulations for electrical connections.



If an over-large load is connected to the inverter's Back-up port, the inverter will protect itself and stop AC output. Please remove some of the load and restart the inverter.

6.2 Electrical Wiring Diagram

System Connection Diagram

This diagram shows Solinteg M2HT-25~50K series hybrid inverter wiring structure and composition, concerning the real project, the installation and wiring have to be in line with the local standards.

Inverter connects with smart meter.

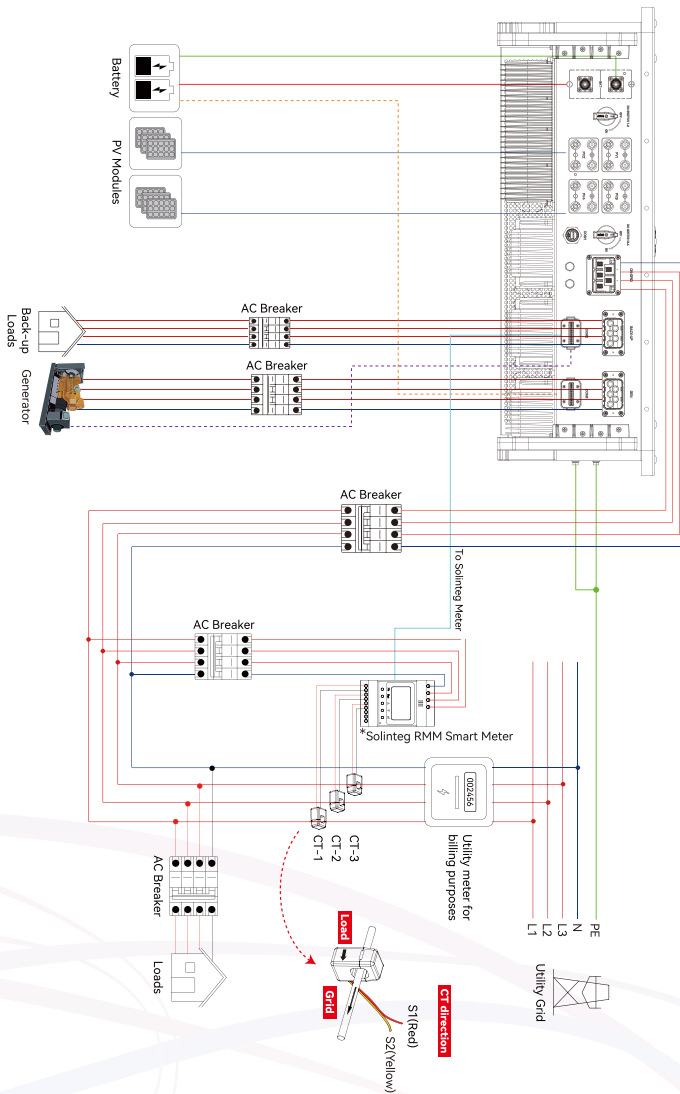

Electrical Connection Diagram

This diagram is an example without special requirement on electrical wiring connection. Neutral line of AC supply can be isolated or switched. Applicable to most countries. Inverter connects with smart meter.

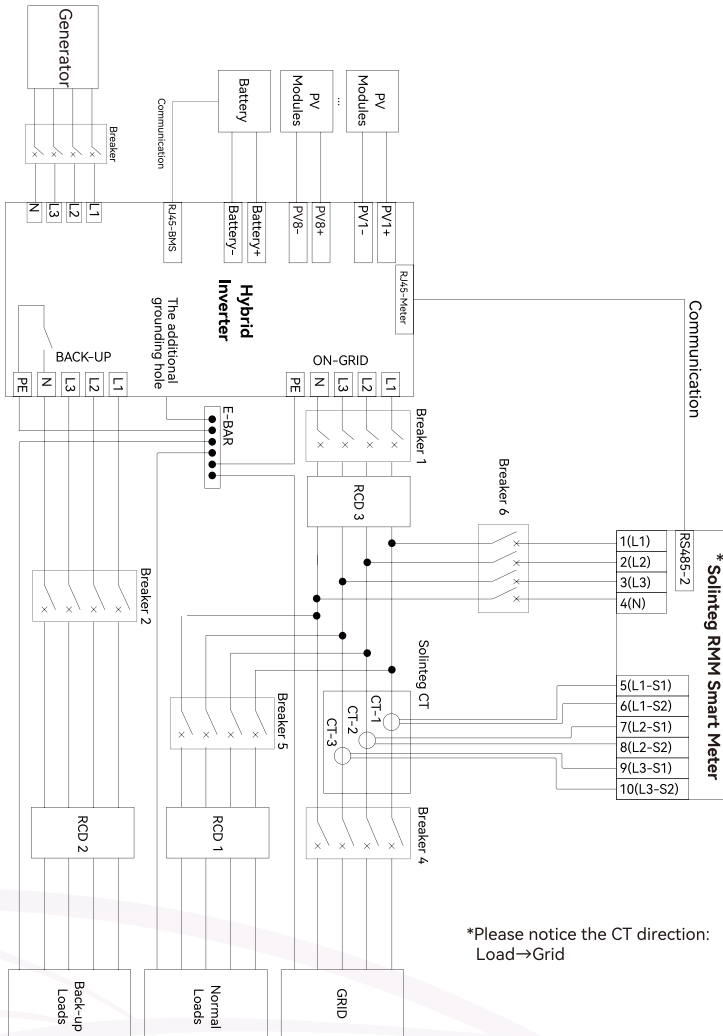

*Please notice the CT direction:
Load→Grid

Inverter connects with 3 CT.

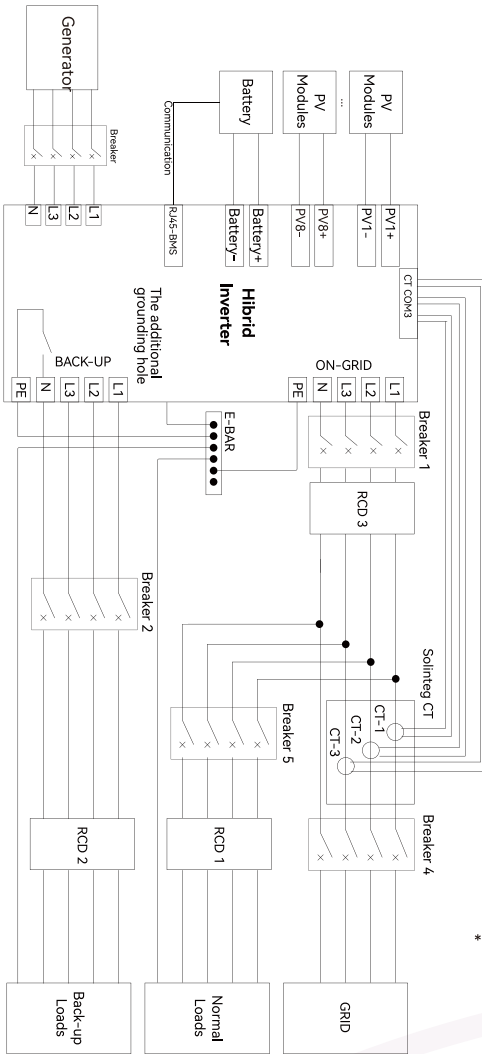

*Please notice the CT direction:
Load→Grid

This diagram is an example for Australia and New Zealand. Neutral line of AC supply must not be isolated or switched, and the neutral line of Grid side and Back-up side must be connected together according to the wiring rules AS/NZS_3000. Otherwise, Back-up function will not work.

Inverter connects with smart meter.

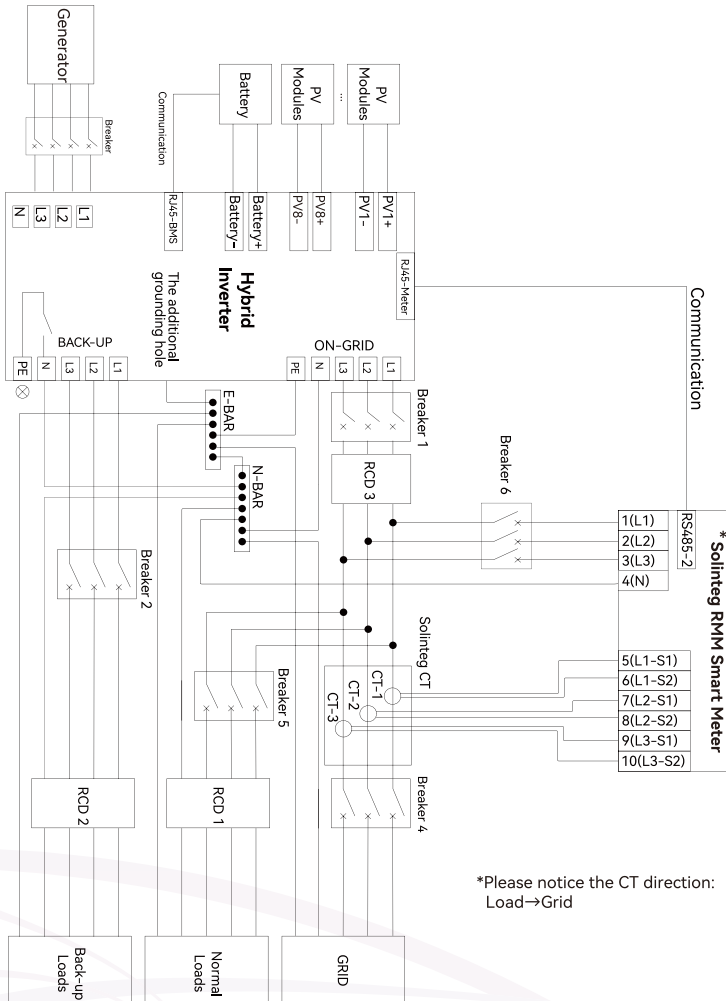

Inverter connects with 3 CT.

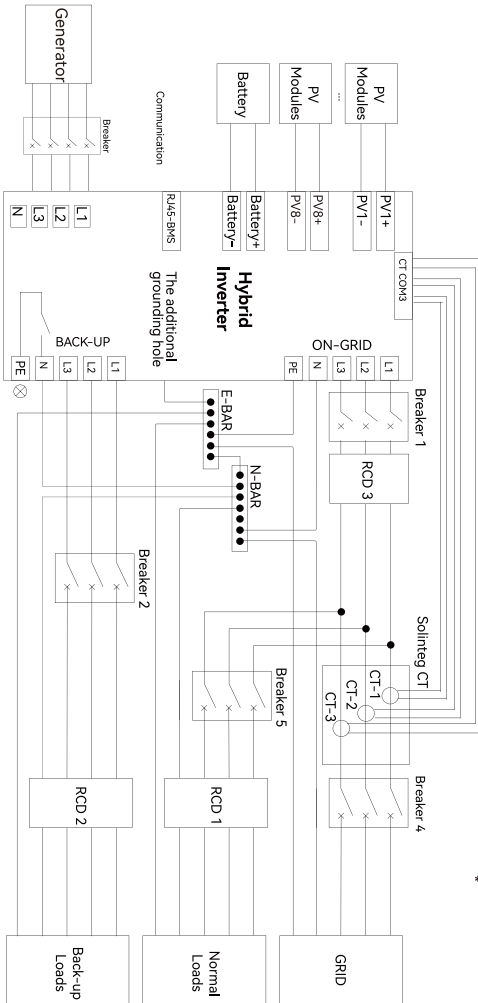

*Please notice the CT direction:
Load→Grid

With an integrated universal residual current communication module, the inverter will disconnect immediately from the mains once a fault current with a value exceeding the limit is detected.

However if an external residual current device (RCD) (type A is recommended) is mandatory, the switch must be triggered at the residual current 300mA. RCD of other specifications can also be used according to local standard.

The electrical wiring diagram provides the following recommendations for the selection of circuit breakers and residual current devices (RCD). Please select based on actual site conditions and local regulations

	M2HT-25K-150	M2HT-29.9/30K-150	M2HT-40K-150	M2HT-50K-150
Breaker 1	100A/400V AC Breaker	125A/400V AC Breaker	160A/400V AC Breaker	160A/400V AC Breaker
Breaker 2	100A/400V AC Breaker	125A/400V AC Breaker	160A/400V AC Breaker	160A/400V AC Breaker
Breaker 3	63A/400V AC Breaker	80A/400V AC Breaker	100A/400V AC Breaker	125A/400V AC Breaker
Breaker 4	Depends on household loads and inverter capacity			
Breaker 5	Depends on normal loads			
Breaker 6	6A/400V AC Breaker			
RCD 1	30mA(type A)	30mA (type A)	30mA (Type A)	30mA (Type A)
RCD 2	30mA(type A)	30mA (type A)	30mA (Type A)	30mA (Type A)
RCD 3	300mA(type A)	300mA (type A)	400mA (Type A)	500mA (Type A)

According to the IEC 62477 standard:

	M2HT-25K-150	M2HT-29.9/30K-150	M2HT-40K-150	M2HT-50K-150
Conditional short-circuit current(kA)	10	10	10	10
Minimum required prospective short-circuit current(kA)	1	1.25	1.6	1.6



NOTE

In accordance with regulatory requirements in Germany, Austria, and other countries, when the inverter operates in off-grid mode, it is necessary to ensure that the neutral (N) line on the Back-up side is grounded to ensure user electrical safety. Once the inverter's "N-PE Check" function is enabled, it will connect the N line to the protective earth (PE) line when operating in off-grid mode, and it will automatically disconnect the N line from the PE line when operating in on-grid mode.

6.3 Preparation of Wiring Tools and Materials

Before proceeding with electrical connections, please prepare the following items:

- ① Inverter accessory kit.
- ② Wiring tools:

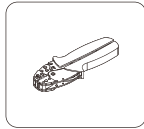

Wire strippers

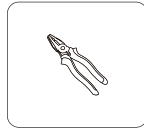

Wire cutters

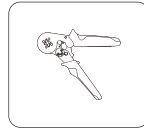

Crimping pliers

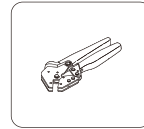

RJ45 connector crimping pliers

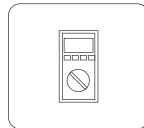

Multimeter
(DC range >1100V)

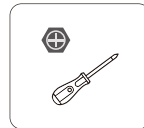

Screwdriver

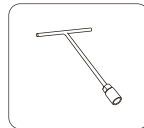

Allen socket wrench

- ③ Cables: AC cables, DC cables, communication cables, grounding cables. (Please prepare suitable cables according to actual conditions)

6.4 AC Connection



WARNING

Before making the connection of AC cable, please confirm all DC & AC power source are disconnected from the inverter.



WARNING

Do not connect the AC cables in the incorrect phase order. Please refer to the labels on the AC connectors.



NOTE

An independent AC breaker is required in both on-grid and back-up output side, and any loads cannot be connected with inverter directly.



Install a residual current device (RCD) on the AC side in accordance with local regulatory requirements.



The Solinteg M2HT-25~50K series three-phase hybrid inverter applies to the three-phase power grid with a voltage of 380V/400V/415V and a frequency of 50/60Hz.



Connect the inverter to the grid only after getting an approval from the local electric power company.

▼ 6.4.1 AC Side Requirements

Cable Preparation

Please select the appropriate cable specifications based on actual conditions. The recommended specifications are as follows.

On-grid side

Name	Cable outer diameter	Conductor cross-sectional area
5-Core AC Cable	20-37mm	16-50mm ²

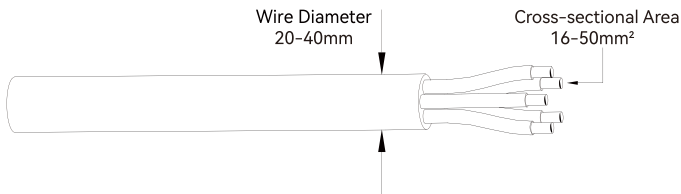

Back-up side and Generator side

Name	Cable outer diameter	Conductor cross-sectional area
5-Core AC Cable	20-30mm	10-25 mm ² (Flexible Cords) 10-35 mm ² (Hard Cords)

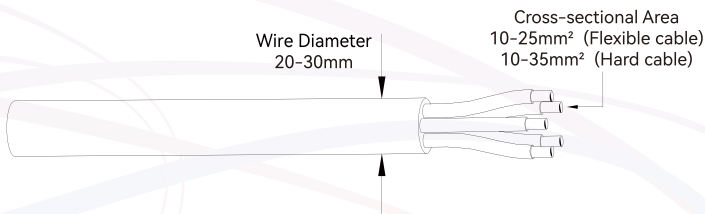

▼ 6.4.2 Wiring Procedure



High voltage may be present in inverter!



Ensure all cables are voltage-free before electrical connection.



Do not connect the AC circuit breaker until all inverter electrical connections are completed.

On-grid AC side

① The recommended outer diameter of the cable is 20-24 mm.

If the outer diameter of the cable is greater than 24.5mm, remove part 1.

If the outer diameter of the cable is greater than 28.5mm, remove part 2.

If the outer diameter of the cable is greater than 32.5mm, remove part 3.

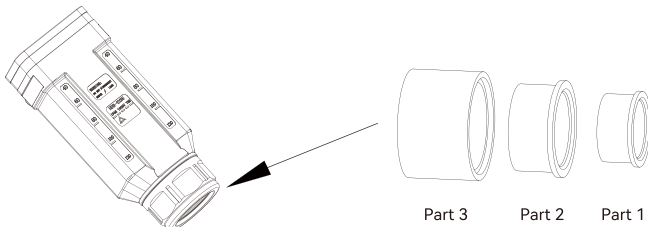

② According to the section 6.4.1, select an appropriate cable, peel the insulation sleeve of AC cable off for 95-100mm, and peel off the end of 3L/N/PE wires for 20-25mm.

It is recommended that the stripping length of 3L cable is 15mm shorter than that of N/PE cable.



- ③ Thread the stripped wire into the lock nut, the plug and the main body in turn.

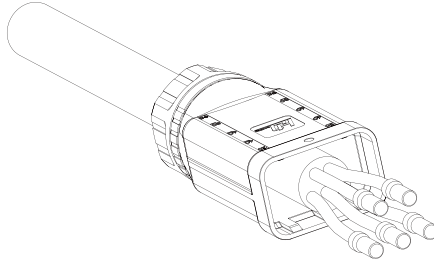

- ④ Use a crimping tool to crimp the cable to the OT terminal.

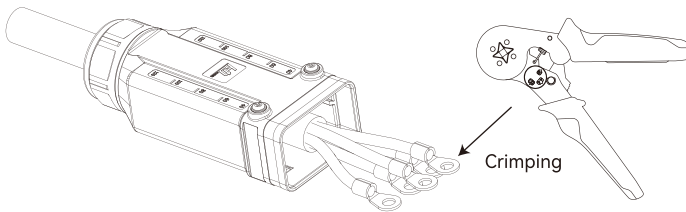

- ⑤ Remove the nut, then install the OT terminals in the order of L1/L2/L3, and tighten the screws to a torque of $3.8 \pm 0.1 \text{ N} \cdot \text{m}$.

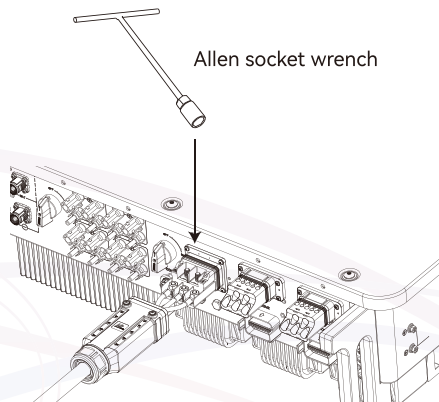

- ⑥ Install the insulating spacer into the designated hole in the rubber core.

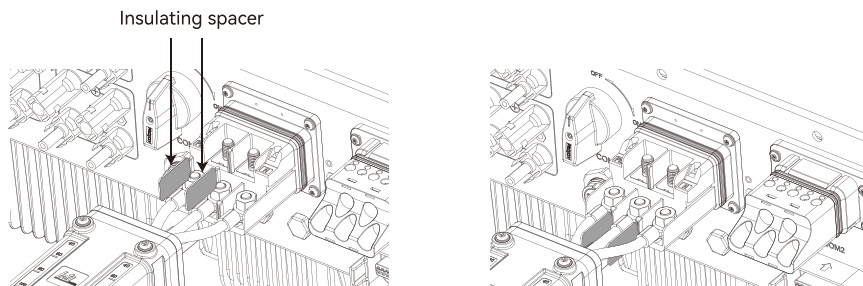

- ⑦ Install the N/PE insulating spacer into the designated hole.

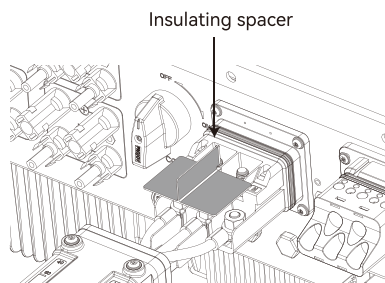

- ⑧ After installing the OT terminals in the order of N/PE, tighten the screws to a torque of $3.8 \pm 0.1 \text{ N} \cdot \text{m}$.

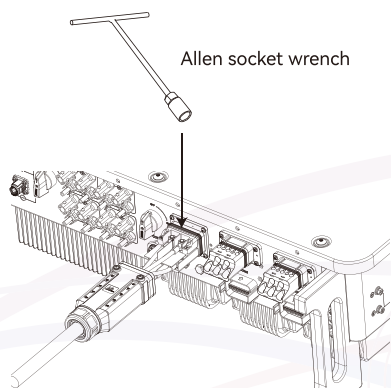

- ⑨ Insert the main body into the panel rubber core, and then tighten the cross screws.

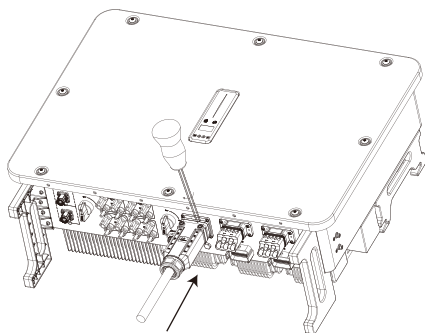

- ⑩ Use an open-end wrench to tighten the nut (torque $10.0 \pm 0.1 \text{N} \cdot \text{m}$), installation completed.

Back-up side and Generator side



Please do not mix up Back-up and Generator connection cables when making the connection to the inverter.

- ① The recommended outer diameter of the cable is 20-24 mm. If the outer diameter of the cable is greater than 24mm, remove part 1 of the sealing ring from the connector housing.

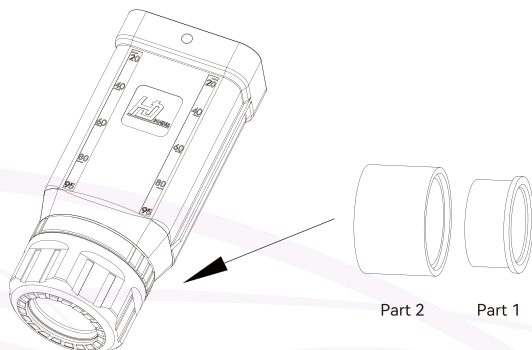

② According to the section 6.4.1, select an appropriate cable, peel the insulation sleeve of AC cable off for 95-100mm, and peel off the end of 3L/N/PE wires for 15mm.

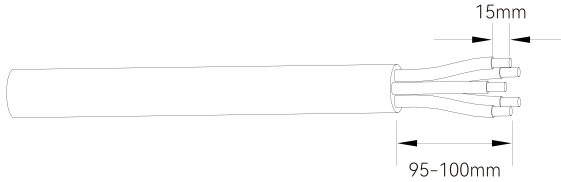

③ Thread the stripped wire into the lock nut and the main body in turn (the multi-core multi-strand copper wire cable needs to be riveted to the cord end terminal).

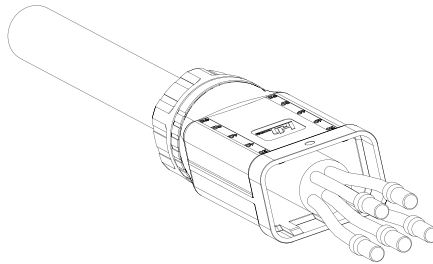

④ Insert the cable into the rubber core according to the line sequence, observe the perspective hole, the cable is in place, and the torque of the crimping screwdriver is $5 \pm 0.1\text{N.m}$.

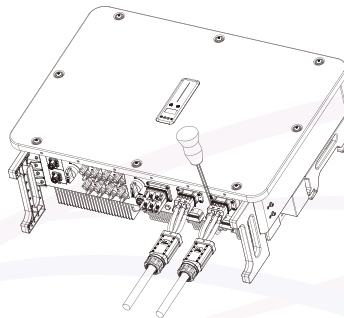



The cord end terminals must be locked tightly, and make sure it won't be loose after a long period of use.

- ⑤ Insert the main body into the rubber core and hear the "click" sound, then tighten the nut with an open-ended wrench (torque $10.0 \pm 0.1 \text{N} \cdot \text{m}$) and complete the installation with a "click".

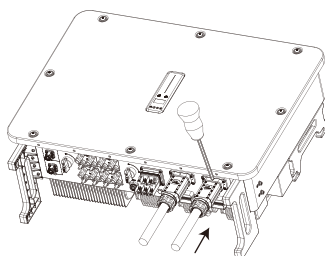

6.5 PV String Connection



When exposed to sunlight, the PV array generates dangerous high DC voltage. Please operate according to our instructions, or it will result in danger to life.



Do not reverse the positive and negative poles of the PV string. Please check the polarity of the PV string first, and after ensuring the correct polarity, connect the PV string to the corresponding terminals of the inverter.



The maximum PV input voltage of the inverter is 950V. If the voltage is greater than 950V but less than 1000V, the inverter will enter standby mode. Voltages greater than 1000V can cause damage to the inverter.



Please ensure that the PV connectors are securely connected to the inverter connectors to prevent overheating or arcing after long-term use.



The brand, model, installation angle, and string voltage of the PV modules connected to the same MPPT should be consistent; otherwise, it may affect the power generation of the inverter.

▼ 6.5.1 PV Side Requirements

Preparation of Materials

Please select the appropriate cable specifications based on actual conditions. The recommended specifications are as follows:

Name	Outside diameter	Conductor cross-section
DC Cable	5.9-8.8 mm	4 mm ² (12AWG) or 6mm ² (10AWG)

System Layout of Units with external DC Switch

- ① Local standards or regulations may require that PV systems install an external DC switch on the DC side of the inverter to ensure isolation.
- ② The DC switch has to be certified by AS 60947.3:2018 and AS/NZS IEC 60947.1:2020 in Australia and New Zealand market. Please refer to the maximum short-circuit current on the inverter DC side to select the appropriate DC switch specifications. We recommend the following electrical connection.

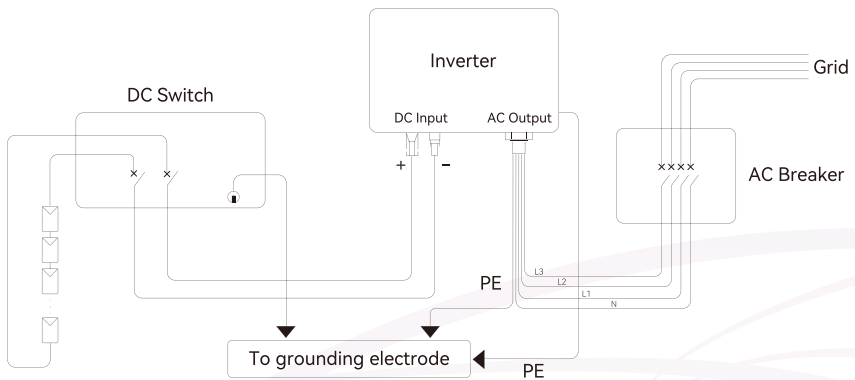

▼ 6.5.2 Wiring Procedure



Before assembling the DC connector, make sure that the cable polarity is correct.

Assembling the PV Connector

- ① Peel off the DC cable insulation sleeve for 7 mm.



- ② Disassemble the PV connector in the accessory bag.

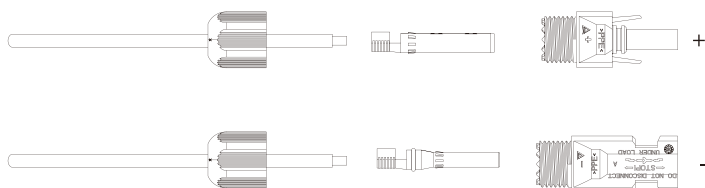

- ③ Insert the DC cable through the DC connector nut into the metal terminal and press the terminal with a professional crimping plier, with the "Phoenix CRIMPFOX-RC 10" being the recommended choice. Pull back the cable with some power to check if the terminal is well connected to the cable.

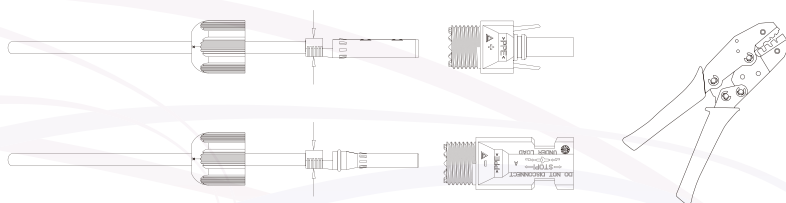

Phoenix CRIMPFOX-RC 10

④ Insert the positive and negative cables into the corresponding positive and negative connectors, pull back the DC cable to ensure that the terminal is tightly attached in the connector.

⑤ To ensure proper sealing of the terminal, use an open-end wrench to securely tighten the nut to the end.

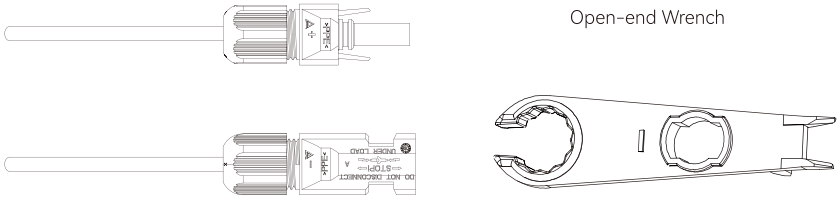

Installing the PV Connector

① Rotate the DC switch to "OFF" position.

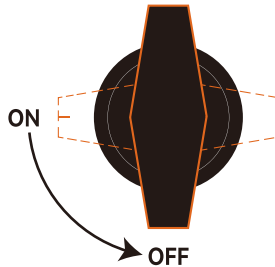

② Check whether the cable polarity of the PV string is correct. The maximum input voltage for the PV string is 950V. If the voltage of PV string ranges from 950V to 1000V, the inverter will enter standby mode. Exceeding 1000V will result in inverter damage.

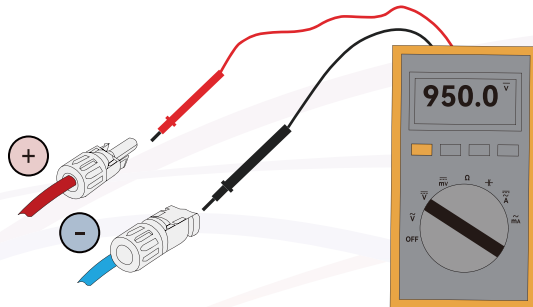

- ③ Insert the positive and negative connectors into the inverter DC input terminals respectively, a click sound should be heard if the terminals are well connected.

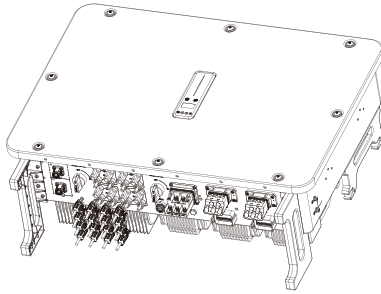

- ④ Seal the unused PV terminals with the terminal caps.

6.6 Battery Connection

This section provides an overview of the battery connection procedures on the inverter side. For details on the battery side connections and configurations, consult the instructions supplied by the battery manufacturer.



WARNING

Please disconnect the AC-side circuit breaker and the battery-side circuit breaker, and set the inverter DC switch to the OFF position before connecting the battery to avoid electric shock.



WARNING

When connecting the battery, ensure that the positive and negative polarities are correct.



CAUTION

The maximum input voltage on the inverter's battery side is 840V. Do not connect a battery with a voltage exceeding 840V.



CAUTION

In the external battery circuit, fuses must be installed on both the positive and negative poles.



The inverter cannot operate off the power grid if no battery is connected.



The inverter only works with batteries listed in our compatibility list; otherwise, the system will not function properly. For a list of compatible batteries with our inverters, please contact the Solinteg service team to obtain it.

▼ 6.6.1 Battery Side Requirements

The M2HT-25~50K inverter is compatible with high-voltage lithium iron phosphate (LFP) batteries equipped with a BMS (Battery Management System) module. Other types of batteries are currently not supported for connection.

Preparation of Materials

Please select the appropriate cable specifications based on actual conditions. The recommended specifications are as follows:

Name	Outside diameter	Conductor cross-section
DC cable	13±0.5mm	50mm ²

▼ 6.6.2 Wiring Procedure



Before initiating the battery connection, ensure that the AC circuit breaker on the grid side and the battery side circuit breaker are disconnected, and the inverter's DC switch is set to the "OFF" position.



Prior to connecting the battery to the inverter, utilize a multimeter to verify the voltage at the battery terminals, making sure it does not exceed 840V.



Ensure the correct polarity of the cables before crimping the battery terminals.

- ① Peel off the battery cable insulation sleeve for 16.5 mm.



- ② Disassemble the battery connector in the accessory bag.

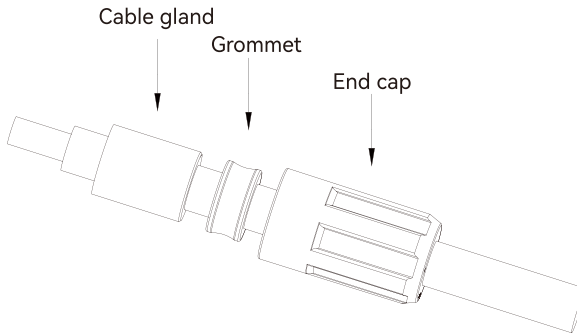

- ③ Insert the battery cable through into the metal terminal of the connector and press the terminal with a professional crimping plier, with the "Phoenix CRIMPFOX 50R" being the recommended choice. Pull back the cable with some power to check if the terminal is well connected to the cable.

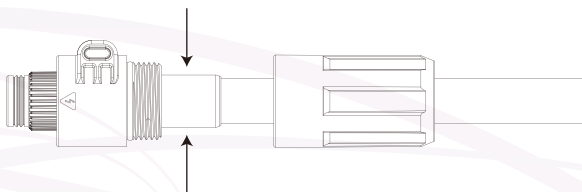

Phoenix CRIMPFOX 50R

④ To ensure proper sealing of the terminal, use an open-end wrench to securely tighten the nut to the end.

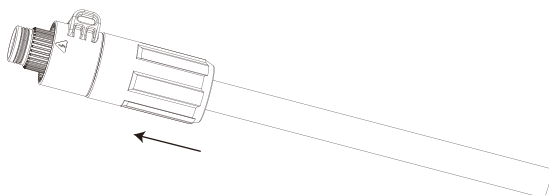

⑤ Insert the positive and negative connector into the inverter battery terminals respectively, and a "click" sound represents the assembly in place.

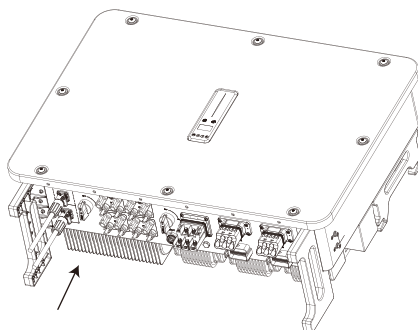

⑥ When pulling out the plug, you need to press the switch button by screwdriver first, and then pull the plug out.

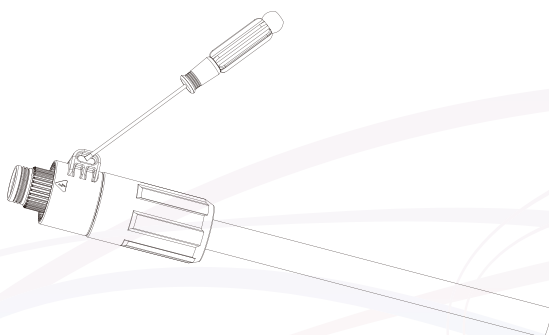

▼ 6.6.3 Battery Communication Wiring

The communication between battery and inverter is RJ45 interface cable. For detailed connection instructions, refer to Section 6.9.3 "Battery Communication".

6.7 Meter and CT Connection

▼ 6.7.1 M2HT-25-50K Connection with 3 CT

The inverter connects to the CT via COM3. The CT should be installed on the L line between the grid and the On-grid side load.

Please refer to the following schematic diagram for connecting the CT.

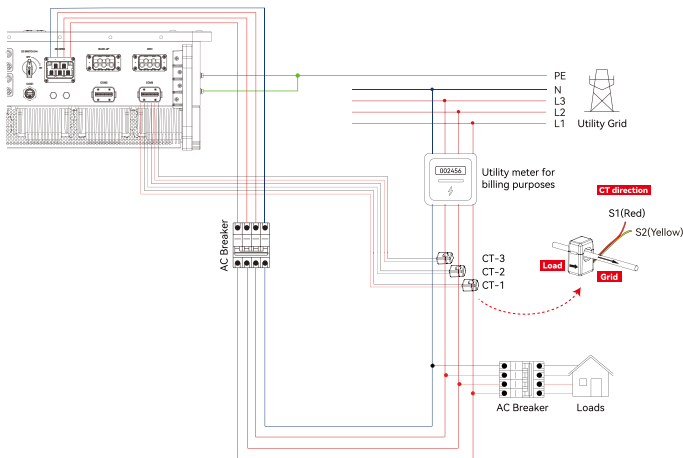

COM3 connector terminal definition:

No.	Port	Description
11	CT-L1 S1	Connect with CT S1
12	CT-L1 S2	
13	CT-L2 S1	Connect with CT S2
14	CT-L2 S2	
15	CT-L3 S1	Connect with CT S3
16	CT-L3 S2	



Please install the CT following the arrow marking on it (Loads→ Grid).

There are three different models of CT. When placing an order, customers should select the appropriate CT based on actual conditions, including the load and the power rating of the inverter.

Specification	Inside diameter	Rated input current	CT Ratio
D16-120A	φ16	120A	1200:1
D24-200A	φ24	200A	2000:1
D35-300A	φ35	300A	3000:1

▼ 6.7.2 M2HT-25-50K Connection with smart meter.

Solinteg M2HT-25~50K hybrid system requires the installation of a smart meter and current transformers (CTs) to enable functions such as load consumption, power limit, and power dispatching.

The smart meter should typically be installed within the AC distribution box or in another suitable location, ensuring it is out of reach of children. The CT must be installed on the live (L) wire between the power grid and the load on the on-grid side.

Both the smart meter and CTs are standard accessories of the inverter packed in the inverter package. The connection between the smart meter and CT is pre-assembled at the factory and should not be disassembled. The CT cable is 2 meters in length.

Please refer to the following schematic diagram for connecting the smart meter and CT.

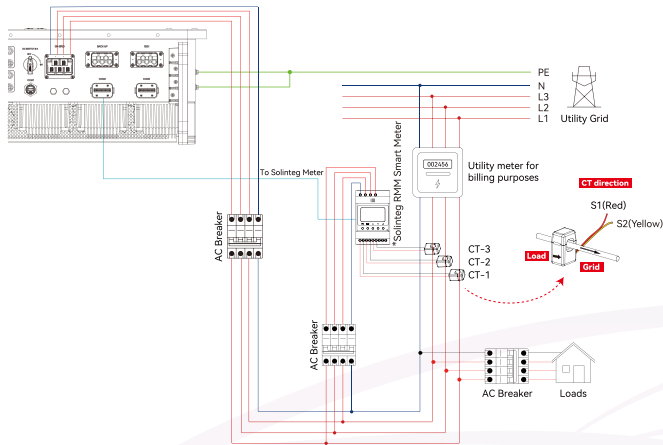

Use only smart meters compatible with Solinteg systems. Connecting non-approved meters may result in certain features not functioning properly.



Install a circuit breaker in the AC side loop of the smart meter.



Please install the CT following the arrow marking on it (Loads→ Grid).

The terminals definitions for the Solinteg RMM three-phase smart meter are as follows

Item	Definition	Function
1	U_{L1}	L1/L2/L3/N connect to grid to detect power grid voltage
2	U_{L2}	
3	U_{L3}	
4	U_N	
5	I_{L1}^*-S1	To detect the CT current and direction
6	I_{L1}^*-S2	
7	I_{L2}^*-S1	
8	I_{L2}^*-S2	
9	I_{L3}^*-S1	
10	I_{L3}^*-S2	
11	PE	Ground connection
RS485	RS485-1	/
	RS485-2	Communicate with hybrid inverter
ANT	/	/
LAN	/	/
Type-C	/	/

There are three different models of CT. When placing an order, customers should select the appropriate CT based on actual conditions, including the load and the power rating of the inverter.

Specification	Inside diameter	Rated input current
D16-120A	φ16	120A
D24-200A	φ24	200A
D35-300A	φ35	300A



When using the RMM-5A smart meter, it is necessary to pair it with 5A CTs. Customers will need to purchase the 5A CTs separately. For detailed instructions on using the smart meter, please refer to the smart meter's user manual.

Wiring diagram

Select a proper system schematic diagram based on the actual situation.

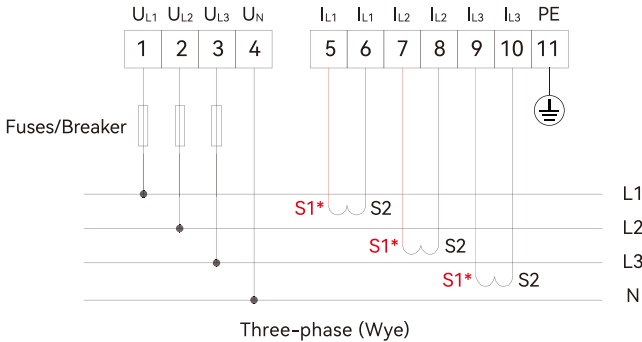

The communication between meter and inverter is RJ45 interface cable. For detailed connection instructions, refer to Section 6.9.2 "Meter Communication".

6.8 Communication Module Connection

The Solinteg M2HT-25~50K inverter is currently only work with the R2MD communication module.



The communication module is shipped together with the inverter in the accessory box.

Connection Steps:

- ① The COM1 port at the bottom of the inverter is designated for connecting the communication module. Begin by rotating and removing the protective cover from the COM1 port.
- ② The COM1 port features a USB interface. Insert the R2MD device into the COM1 port until it is fully inserted. Rotate the nut until you hear an audible 'click,' indicating that the connection is secure.

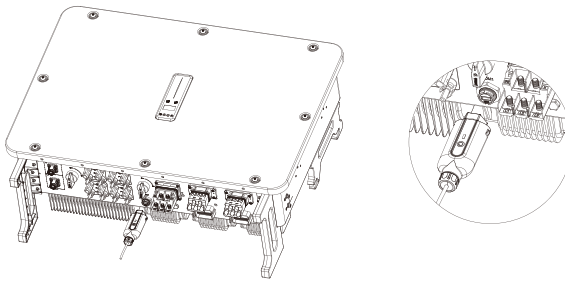

6.9 Communication Connection

The M2HT-25~50K inverter communicates with external devices through the ports in

Port definitions for the COM2 multi-function connector

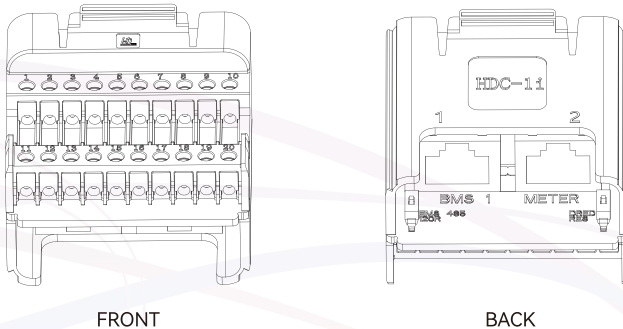

FRONT

BACK

Front Side

NO	Port	Function	NO	Port	Function	
1	REF/0	Connect DRED/RCR devices DRED For Australia and New Zealand RCR For Germany and some other European countries	11	DO 1	NO	Digital output port for diesel generator or start-stop smart load control (optional)
2	COM/0		12		COM	
3	D 1/5		DO 2	13	NO	Reserved
4	D 2/6			14	COM	
5	D 3/7		EMS. STOP	15	IN+	Connect the Emergency Stop device. Normally open (NO) and normally closed (NC) status (Optional)
6	D 4/8			16	IN-	
7	DO3 NO	Reserved	17	DI 1	IN+	Digital input from ATS device
8	DO3 COM		18		IN-	
9	BK NC	Connect Back-up box	19	EMS 485	A	Communicate with the EMS device
10	BK Com		20		B	

Back Side

NO	Port	Function
1	BMS 1 (RJ45)	Communicate with battery
2	METER (RJ45)	Communicate with smart meter RMM
/	EMS 485 120R (DIP Switch)	EMS communication termination resistor switch
/	DRED RES (DIP Switch)	DRED detection resistor 10kΩ Deactivate this detection resistor when using the DRED function

Port definitions for the COM3 multi-function connector

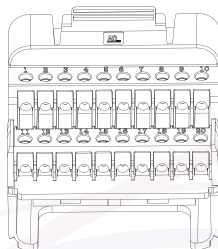

FRONT

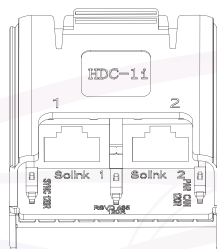

BACK

Front Side

NO	Port	Function	NO	Port	Function	
1	DI2 IN+	Reserved	11	CT-L1	S1	Contact L1 CT
2	DI2 IN-		12			
3	RSVD 485A		CT-L2	13	S1	Contact L2 CT
4	RSVD 485B			14	S2	
5	RSVD1		CT-L3	15	S1	Contact L3 CT
6	RSVD2			16	S2	
7	12V+	12V output	17	EV 485	A	Communicate with EV charger
8	12V-		18		B	
9	RSVD3	Reserved	19	BMS 2	H	Reserved
10	RSVD4		20		L	

Back Side

NO	Port	Function
1	Solink 1 (RJ45)	For parallel system communication between Solinteg hybrid inverters, or for connecting other Solinteg devices
2	Solink 2 (RJ45)	
/	SYNC 120R (DIP Switch)	Synchronization signal termination resistor for parallel systems. In the parallel system, the termination resistor needs to be activated on the first and last inverters
/	PAR CAN 120R (DIP Switch)	communication termination resistor for parallel systems. In the parallel system, the termination resistor needs to be activated on the first and last inverters
/	RSVD 485 120R (DIP Switch)	Reserved

RJ45 terminal connection sequence and definition as below:

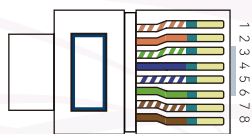

No.	Color	BMS 1	METER	Solink 1	Solink 2
1	Orange & White	/	/	Sync+	Sync+
2	Orange	/	/	Sync-	Sync-
3	Green & White	Encode_B	485 B2	12V-	12V-
4	Blue	CANH_B1_OUT	/	CANH_P	CANH_P
5	Blue & White	CANL_B1_OUT	/	CANL_P	CANL_P
6	Green	Encode_A	485 A2	12V-	12V-
7	Brown & White	CANL_DEBUG	485 B2	12V+	12V+
8	Brown	CANH_DEBUG	485 A2	12V+	12V+

▼ 6.9.1 Wiring Procedure

Assembling the Multi-function Connector

- ① Unscrew the swivel nut from the connector.

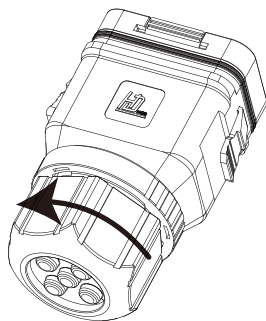

- ② Take out the terminal block.

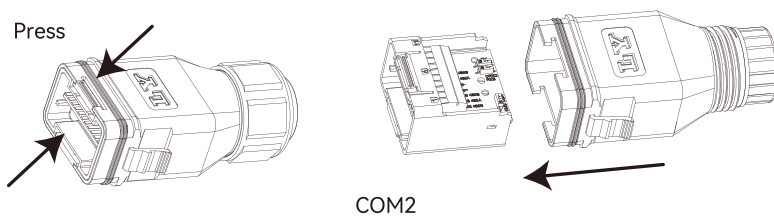

- ③ Remove the seal and lead the cable through the cable gland.

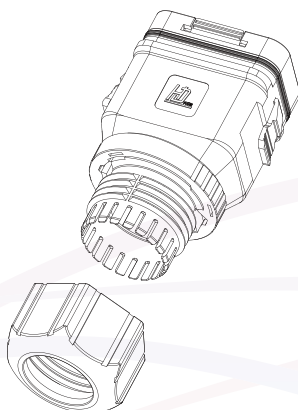

Terminal Block Wiring

① Thread the cable of appropriate length through the swivel nut and the housing. Remove the cable jacket and strip the wire insulation.

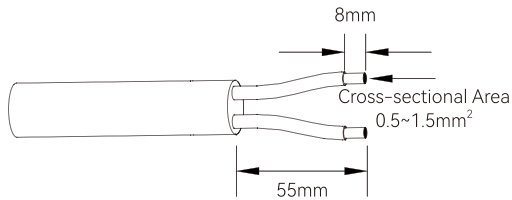

② (Optional) When using a multi-core multi-strand copper wire cable, twist the wires together by hand into a bundle and then press them into the terminal. In case of single-strand copper wire, skip this step.

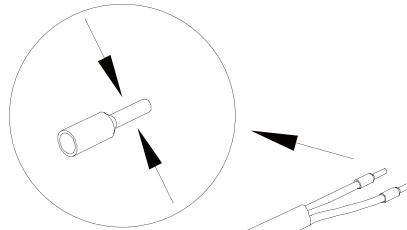

③ Fix all the wires to the terminal plug according to the assignment and tighten to a torque of $1.2\pm 0.1\text{N}\cdot\text{m}$ with a screwdriver.

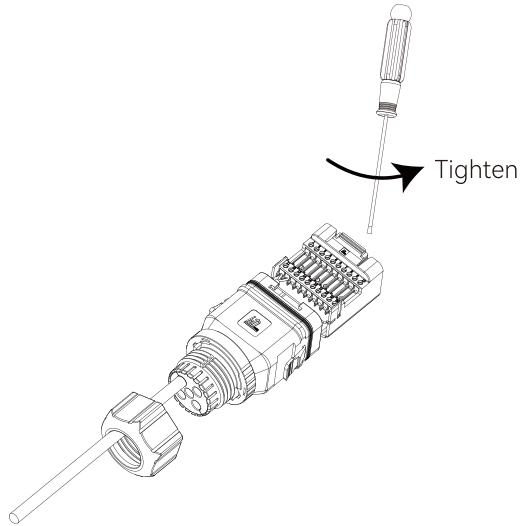

④ Pull the wires outward to check whether they are firmly installed. Insert the terminal block into the connector until it snaps into place with an audible click.

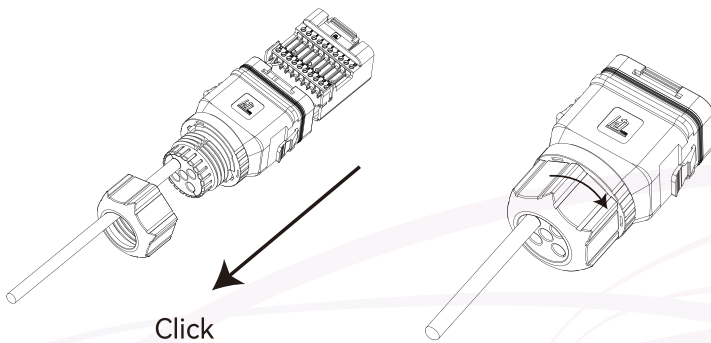

RJ45 Port Wiring

- ① Use an RJ45 crimping tool to attach an RJ45 connector.
- ② Thread the RJ45 plug of appropriate length through the swivel nut, and insert it into the open side of the rubber gasket. Insert one side of the RJ45 plug into the RJ45 port of terminal block.

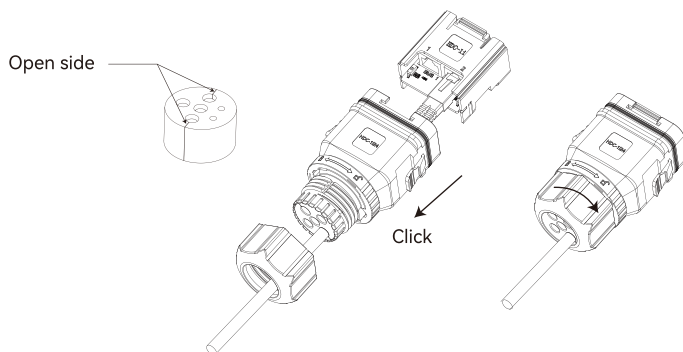

- ③ Insert another side of the communication cable into the communication port of the external device.

Insert the COM2 and COM3 connectors into the corresponding ports of the inverter.

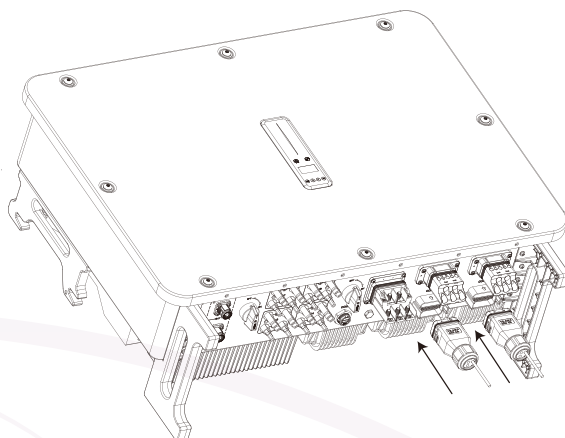

Please distinguish between COM2 and COM3 terminals. COM3 terminal is blue.

▼ 6.9.2 Meter Communication

The inverter communicates with the smart meter through the RS485 communication line.



The communication cable is shipped together with the inverter in the accessories box.

The wiring diagram is as follows.

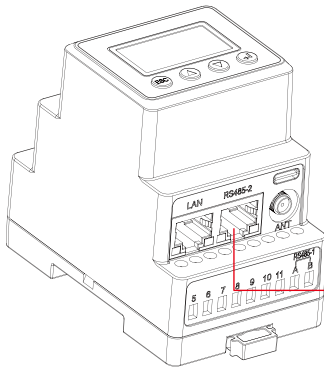

Solinteg RMM Meter

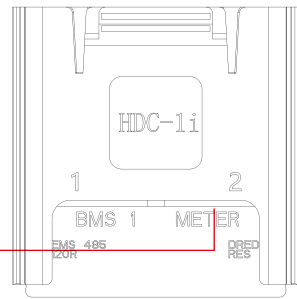

COM2

RJ45 terminal of Meter connection sequence and definition as below:

RJ45	No	Color	METER
	1	Orange & White	/
	2	Orange	/
	3	Green & White	485 B2
	4	Blue	/
	5	Blue & White	/
	6	Green	485 A2
	7	Brown & White	485 B2
	8	Brown	485 A2

▼ 6.9.3 Battery Communication

The inverter communicates with the BMS of the battery through the CAN communication line.



The communication cable is included with the unit and is located in the accessories box.

RJ45 terminal of BMS 1 connection sequence and definition as below:

RJ 45	No	Color	BMS 1
	1	Orange & White	/
	2	Orange	/
	3	Green & White	Encode_B
	4	Blue	CANH_B1_OUT
	5	Blue & White	CANL_B1_OUT
	6	Green	Encode_A
	7	Brown & White	CANL_DEBUG
	8	Brown	CANH_DEBUG



Do not ground or connect unused battery communication cables to other devices.



Please use the BMS 1 port for battery communication, the BMS 2 port is invalid.

▼ 6.9.4 EV Charger Communication

The inverter communicates with the EV charger through the RS485 communication line.



The EV charger should be well grounded. Otherwise, it will affect the communication between the EV charger and the inverter.



The EV charger should be Solinteg ECA series .

The wiring diagram is as follows:

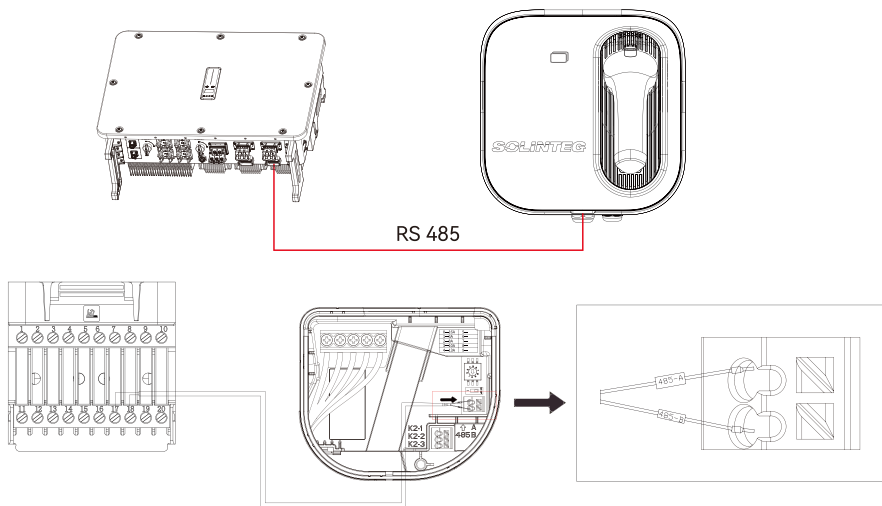

▼ 6.9.5 DRED/RCR

DRM and Ripple Control support only one function at the same time.

DRED

DRED (Demand Response Enabling Device) interface is special reserved for Australia and New Zealand according to their safety regulation, and Solinteg doesn't provide the DRED device for the customer. The inverter supports the demand response modes as specified in the standard AS/NZS 4777. The inverter has integrated a terminal block for connecting to a DRED.

DRED wiring diagram (hybrid inverter) as below:

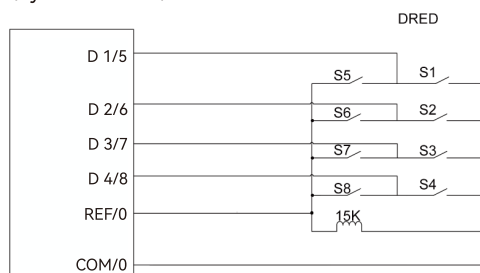

DRED mode as shown in table below:

Mode	Function
DRM 0	Operate the disconnection device
DRM 1	Do not consume power
DRM 2	Do not consume at more than 50% of rated power
DRM 3	Do not consume at more than 75% of rated power and source reactive power if capable
DRM 4	Increase power consumption (subject to constraints from other active DRM's)
DRM 5	Do not generate power
DRM 6	Do not generate at more than 50% of rated power
DRM7	Do not generate at more than 75% of rated power and sink reactive power if capable
DRM8	Increase power generation (subject to constraints from other active DRM's)
Priority	DRM1>DRM2>DRM3>DRM4 DRM5>DRM6>DRM7>DRM8



When using the function of DRED, please set the DRED detection resistor switch to "OFF".

RCR

RCR (Ripple Control Receiver) interface is special reserved for Germany and some other European countries according to their safety regulation, and Solinteg doesn't provide the RCR device for the customer.

In Germany and some European areas, a ripple control receiver is used to convert a power grid dispatching signal to a dry contact signal. The dry contact is required for receiving the power grid dispatching signal.

RCR wiring diagram (hybrid inverter) as below:

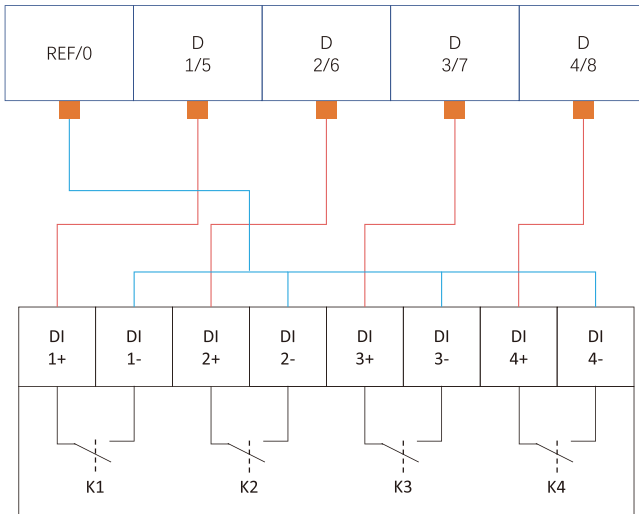

Ripple Control Receiver

RCR operation mode as shown in table below:

Switch mode (External RCR device)	Feed-in output power (in % of the Rated AC output power)
K1 turn on	100%
K2 turn on	60%
K3 turn on	30%
K4 turn on	0%

RCR priority: K1<K2<K3<K4

▼ 6.9.6 Emergency Stop

Solinteg M2HT-25~50K hybrid inverter comes standard with emergency stop function, and you can use this function by connecting an external switch into the emergency stop interface if it requires in the installation place. The external switch doesn't include in our accessory box. When the emergency stop function is activated, the inverter will stop AC-side output.

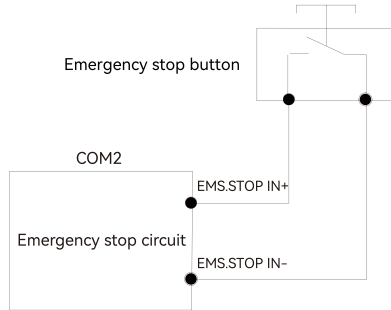

The dry contact associated with the emergency stop switch can be set via the inverter's screen. Users have the option to configure the switch as a normally open (NO) or normally closed (NC) contact according to their system requirements.

▼ 6.9.7 Load Control

When paired with Solinteg additional control device, Solinteg M2HT-25~50K inverter can achieve load control functions, including control for SG-ready heat pumps.



For more details on Solinteg additional control device, please contact Solinteg service team.



Maximum voltage and current at DO dry contact port: 30VDC 1A.

▼ 6.9.8 Parallel System

The following instances demonstrate wrong practices in parallel operation.

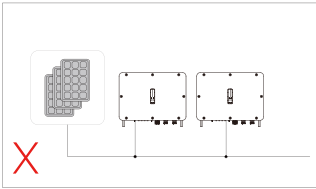

① Single PV string cannot connect to multiple inverters.

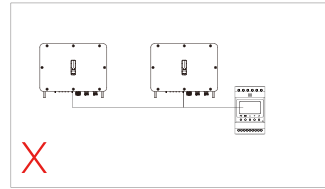

② One meter cannot be connected to multiple inverters. Different CTs cannot connect to the same line cable.

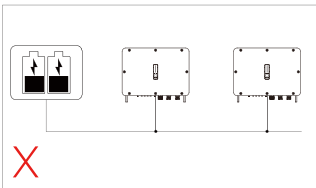

③ One battery bank cannot be connected to multiple inverters.

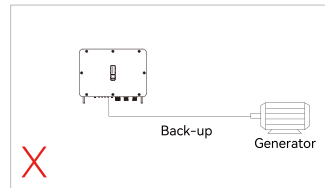

④ The back-up side cannot be connected to the generator directly.

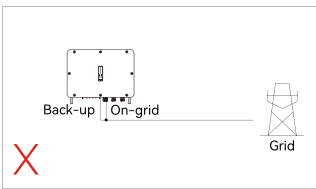

⑤ The back-up side cannot be connected on grid side or grid.



CAUTION

Testing to AS/NZS 4777.2:2020 for multiple inverter combinations has not been conducted. Multiple inverter combinations should not be used in the AU market.

The M2HT-25-50K series inverters support up to 10 units on-grid side paralleling and 4 units on/off-grid side paralleling.

The on-grid parallel system must meet the following conditions:

- ① Inverters of different power ratings within the M2HT-25-50K series can be paralleled.
- ② The parallel system operates in a master-slave configuration. One inverter must be designated as the master, and the others as slaves, either through the inverter's display or the monitoring platform.
- ③ The master inverter must communicate with the smart meter via RS485. The inverters communicate with each other through CAN.
- ④ Each inverter must be equipped with a communication device.
- ⑤ In the parallel system, circuit breakers must be installed on the output of both On-grid and Back-up sides.
- ⑥ In the parallel system, the DIP switches for the Sync 120R and PAR CAN 120R termination resistors on the first and last inverters need to be set to "ON"

The on/off-grid parallel system must meet the above six conditions, and it also needs to be equipped with Solinteg back-up side device (Solinteg EDA controller/box/cabinet):

- ① The master inverter must communicate with Solinteg back-up side device via DO port.

The electrical connection and communication connection diagram for the on-grid parallel system is as follows:

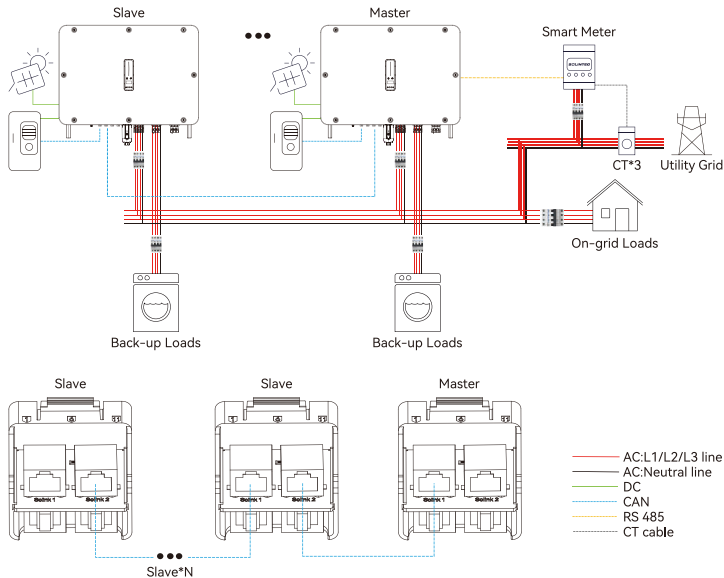

The electrical connection and communication connection diagram for the on/off-grid parallelsystem is as follows:

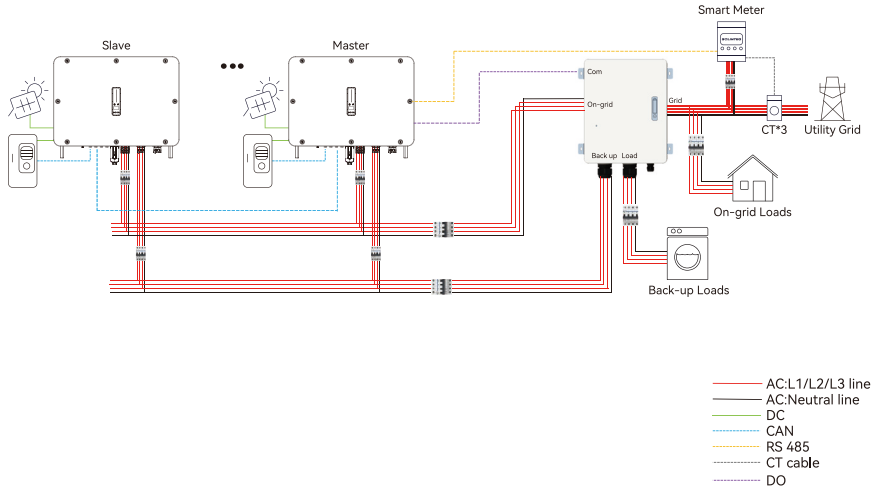

For more information about on/off-grid parallel of the M2HT-25-50K series inverters, please learn from Solinteg EDA device user manual or contact Solinteg service team.

7 Commissioning

7.1 App Preparation

- ① Install the Cloud monitoring App with latest version.
- ② Register an account on the Cloud monitoring App. If you have got the account and password from the distributor/installer or Solinteg, skip this step.

7.2 Inspection Before Commissioning

Check the following items before starting the inverter:

- ① All equipment has been reliably installed.
- ② DC switch and AC circuit breaker are in the "OFF" position.
- ③ The ground cable is properly and reliably connected.
- ④ The AC cable is properly and reliably connected.
- ⑤ The DC cable is properly and reliably connected.
- ⑥ The communication cable is properly and reliably connected.
- ⑦ The vacant terminals are sealed.
- ⑧ No foreign items, such as tools, are left on the top of the machine or in the junction box (if there is).
- ⑨ The AC circuit breaker is selected in accordance with the requirements of this manual and local standards.
- ⑩ All warning signs & labels are intact and legible.

7.3 Commissioning Procedure

If all of the items mentioned above meet the requirements, proceed as follows to start up the inverter for the first time.

- ① Turn on the AC breaker.
- ② Turn on the lithium battery switch. Power on the battery pack manually if a battery is equipped.
- ③ Turn on the DC switch, the DC switch may be integrated in the inverter or installed by the customer. Please wait for 5 minutes.
- ④ The inverter will operate properly if the PV and the grid meet inverter startup requirements. The time required for the inverter to connect to the grid may take a few minutes or longer, depending on the national/regional safety code selected during the initial setup and the actual grid conditions.
- ⑤ Observe the LED indicator to ensure that the inverter operates normally.

④ After the inverter is started, please refer to the [Quick Installation Guide] for instructions on network configuration and other settings.



NOTE

If the inverter does not work properly, check the country code and battery ID Settings.

- ① Select the safety code suitable for the country (region) where the inverter is installed at.
- ② Select the battery ID suitable for the battery is installed.



NOTE

CT AUTO TEST FUNCTION

M2HT-25~50K hybrid inverter has the function of detecting the installation direction and phase sequence of CTs. The system is installed, this function can be enabled on the APP for detection.



CAUTION

SOC RESET FUNCTION

When this function is enabled, the battery will be automatically charged to calibrate the battery SOC. After the battery is fully charged, this function will be turned off automatically (It can be manually turned off if there is insufficient energy to fully charge the battery). We recommend performing a calibration once during the initial installation and then periodically thereafter.

7.4 Stop the Inverter

When turning off the inverter, please follow the steps below:

- ① Shut down the inverter through the APP or the button on the display first.
- ② Disconnect the breakers on the grid and load side.
- ③ Turn off the battery switch, and disconnect the DC breaker on the battery side (if any).
- ④ Wait 30 seconds and then turn the inverter DC switch to the "OFF" position. At this time, there is remaining power in the inverter capacitor. Wait for 10 minutes until the inverter is completely de-energized before operating.
- ⑤ If need to turn on the inverter after following above steps to stop the inverter, please turn on the AC breaker, battery breaker, battery switch and DC switch in turn, then the inverter will start.
- ⑥ If the inverter is not used for some time or never again, please disconnect the AC and DC cables. Please notice disconnection cables is only for disconnection and requires an electrician/trained approved personnel.

8 Operation

8.1 Indicator

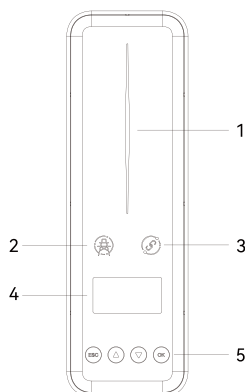

Item	Indicator	Status	Description	
1	Power and Alarm Indicator	Off	No power.	
		Blue	Quick flashing	Inverter entered self-test status.
			Slow flashing	Inverter entered waiting status.
			Breathe flashing	Inverter works normal.
		Orange	Breathe flashing	Low battery warning, the battery power is about to reach the SOC protection value.
Red	Always on	An alarm or fault is detected, view the fault info on the display.		
2	Grid Indicator	Off	Grid lost.	
		Slow flashing	Inverter detected grid but not running in on-grid mode.	
		Always on	Inverter works in on-grid mode.	
3	Communication Indicator	Green	Always on	The inverter communication is running normally.
			Flashing	The inverter communicates with EMS or Master inverter through RS485 or CAN.
		Orange	Always on	The inverter isn't communicating with Solinteg smart meter.
		Red	Always on	The inverter isn't communicating with the BMS.
4	Display	Display the inverter's operational status, parameter settings, etc. Display off to save power, press the button to wake up the display.		
5	Button	Switch display information and set parameters.		

8.2 OLED display

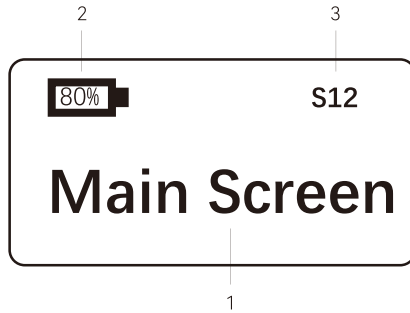

Item	Description
1	Display the inverter’s basic information, operating status, parameter settings, etc.
2	Display the battery SOC (State of Charge).
3	Status code of inverter. Please refer to Section 10.1 "Status code in waiting".

8.3 Button

Symbol	Button	Description
	ESC	Exit the current interface/return/cancel edit.
	Up	Move the cursor up or adjust the value.
	Down	Move the cursor down.
	Enter	Enter the next level menu/confirm selection/enter edit mode.

*Long press the 3s ESC button to restart the screen.

8.4 Screen Menu

▼ 8.4.1 Main Screen

Inverter in On-grid status:

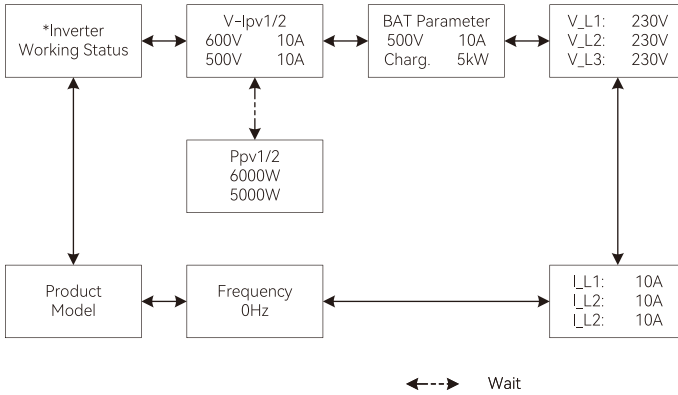

Inverter in Off-grid status:

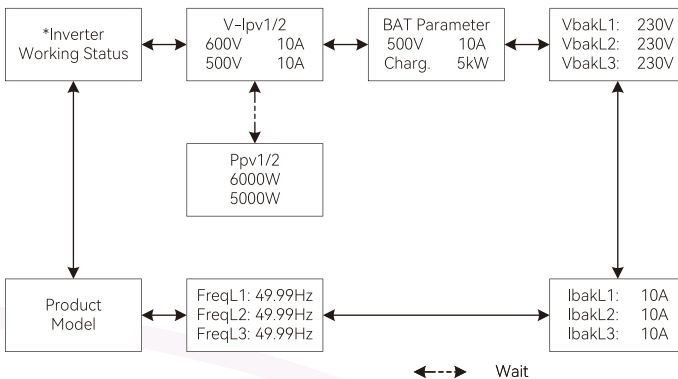

*Inverter working status: Waiting/Checking/On-Grid/Off-Grid/Fault Info/FW Updating

Item	Description
V- <i>Ip</i> 1/2	PV input voltage and current of each MPPT
V- <i>Ip</i> 3/4	PV input voltage and current of each MPPT
Ppv1/2	PV input power of each MPPT
Ppv3/4	PV input power of each MPPT
BAT Parameter	Battery Parameter
Charg	Battery charge
Dischg	Battery discharge
V _{L1} / V _{L2} / V _{L3}	Three-phase AC voltage (On-Grid status)
VbakL1 / VbakL2 / VbakL3	Three-phase AC voltage (Off-Grid status)
I _{L1} / I _{L2} / I _{L3}	Inverter output current (On-Grid status)
IbakL1 / IbakL2 / IbakL3	Inverter output current (Off-Grid status)
Frequency	Inverter output Frequency(On-Grid status)
FreqL1 / FreqL2 / FreqL3	Inverter output Frequency (Off-Grid status)
Fault Info	Fault Information

▼ 8.4.2 Setting Menu

Inverter OLED Screen Menu

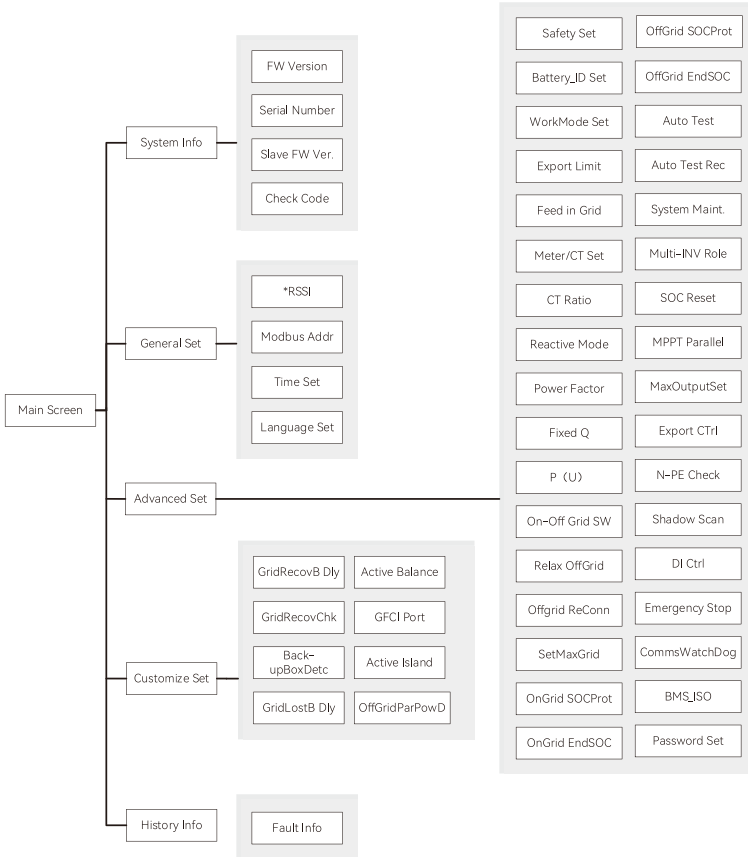

*This menu is displayed during Wi-Fi communication and is not shown during LAN communication.



After setting, select "Yes" to save the settings, or select "No" to cancel the operation or not save the settings.

Save the result?
Yes No

***After setting,
Select "Yes" to save the result.
Select "No" to cancel the set operation/not save the result.

System Info

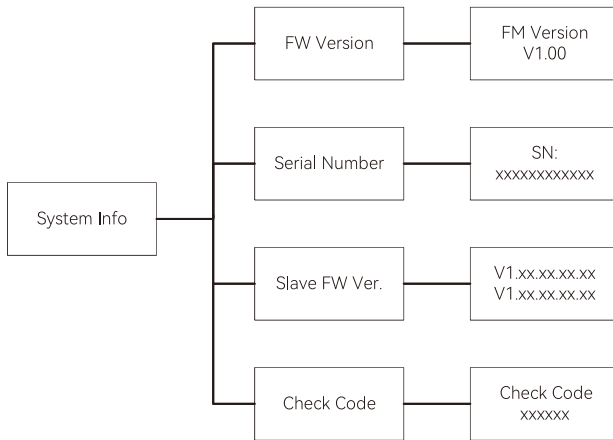

Item	Description
FW Version	Firmware version (Not editable)
Serial Number	Serial Number (Not editable)
Slave FW Ver.	Slave Firmware version (Not editable)
Check code	Inverter check code (Not editable)

General Set

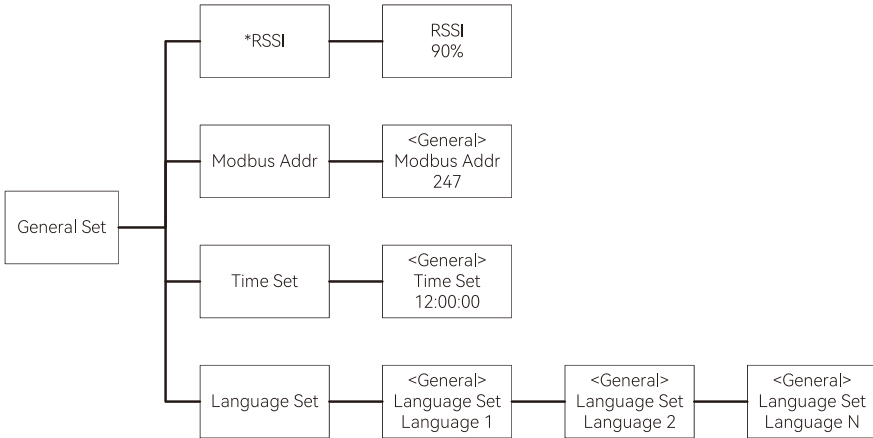

Item	Description
RSSI	Received signal strength under Wi-Fi communication (Not editable).
Modbus Addr	Modbus address of inverter.
Time Set	Set the inverter's RTC (Real-Time Clock) time.
Language Set	Set the display language for the inverter screen.

*This menu is displayed during Wi-Fi communication and is not shown during LAN communication.

Advanced Set

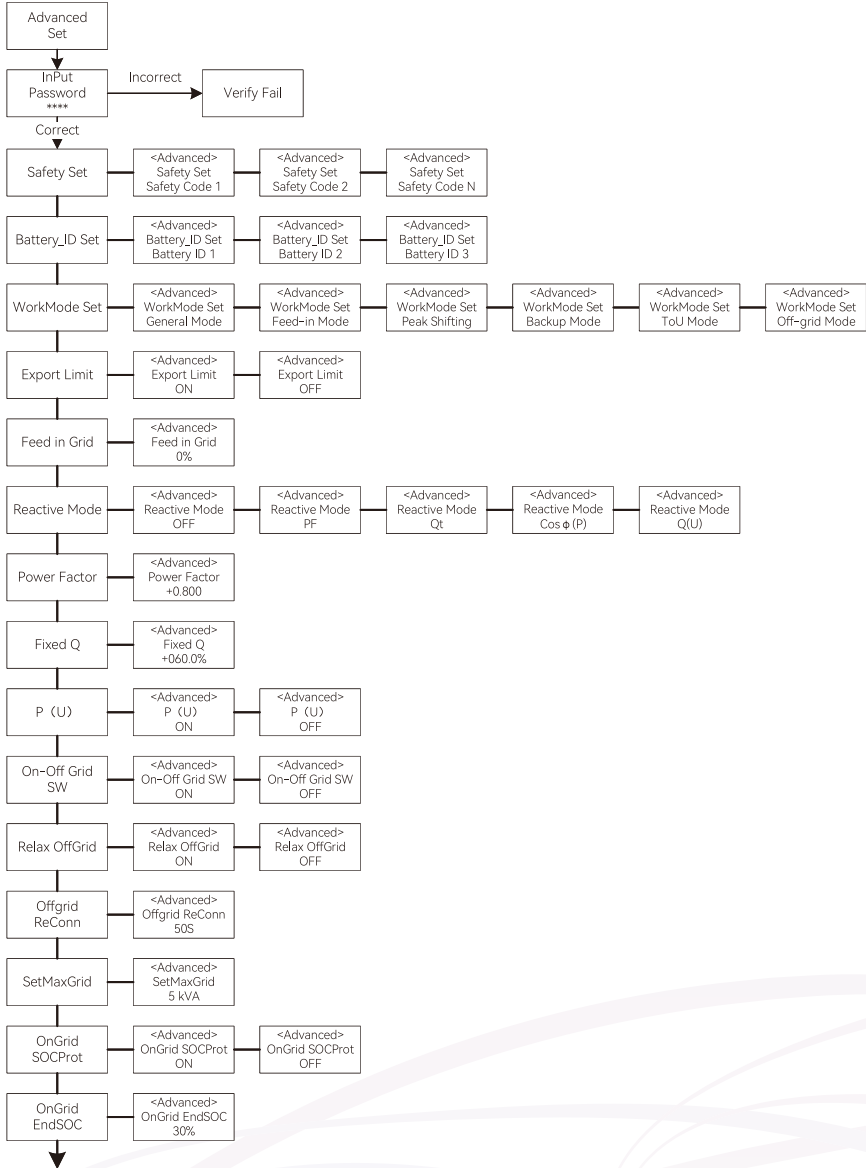

To the next page

From the previous page

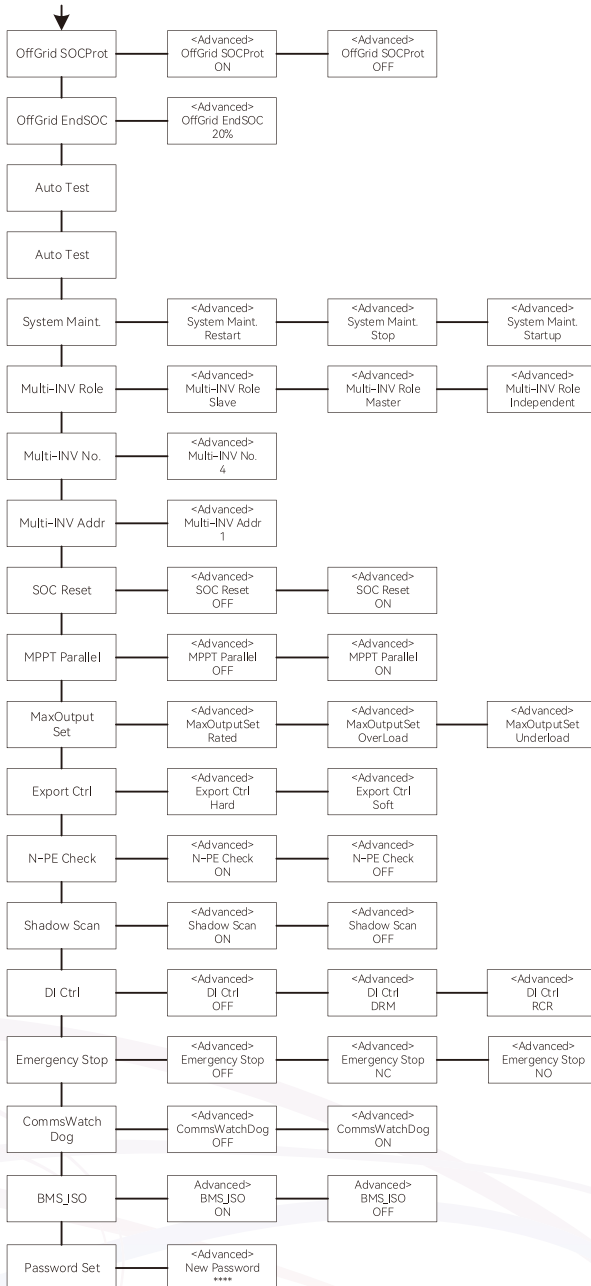

Item	Description
Safety Set	Please select the safety code according to local regulatory requirements, or contact the installer or Solinteg service team (service@solinteg.com).
Battery_ID Set	Select the battery model. Select the correct battery ID. Otherwise, communication between the inverter and the battery will be abnormal.
Work Mode	Operation mode selection General Mode/Backup Mode/Peak Shifting/Feed-in Mode/Off-grid Mode/ToU Mode. For detailed introductions of specific operation modes, please refer to Section 3.4.1 "Operation Modes".
Export Limit	On-grid export limit function switch.
Feed in Grid	Set the percentage of the power that is allowed to feed to the grid.
Meter/CT Set	Select Meter or CT for export limit
Reactive Mode	Reactive power mode selection. The inverter can output reactive power in the following modes: OFF: Disable this function. PF: The reactive power can be regulated by the parameter PF (Power Factor). Qt: The reactive power can be regulated by the parameter Q-Var limits (in %). Cos(ϕ)P: The PF changes with the output power of the inverter. Q(U): The reactive power changes with the grid voltage. The specific parameters for reactive power modes can be set through the monitoring platform or APP.
Power Factor	In PF mode of reactive mode, the inverter inputs reactive power according to the set power factor.
Fixed Q	In Qt mode of reactive mode, the inverter outputs a fixed value of reactive power.
P(U)	P(U) curve switch. The inverter outputs active power based on the changes in the grid voltage.
On-Off Grid SW	Off-grid function switch (If turn it on, the inverter will automatically switch to off-grid mode to ensure the back-up side power supply when the grid is abnormal or off, otherwise, there is no output on the back-up side). Turn on this switch, and HVRT (High Voltage Ride Through) and LVRT (Low Voltage Ride Through) functions will be disabled.
Relax OffGrid	Reduce the switching sensitivity of the On/Off-grid (applied to the places where the grid is unstable or inverter always entered off-grid mode for some reasons).
Offgrid ReCon	When operating off-grid, after overload protection, the inverter will stop the output on the back-up side and then restart within the set time period.

Item	Description
SetMaxGrid	Set max allowed power from grid (under the condition of Peakload Shifting is on).
OnGrid SOCPort	On-grid battery SOC protection.
OnGrid EndSOC	End-of-discharge SOC of on-grid.
OffGrid SOCPort	Off-grid SOC protection.
OffGrid EndSOC	End-of-discharge SOC of off-grid.
Unbalan.Output	3-Phase unbalanced output switch.
Auto Test	CEI 0-21 auto test.
System Maint.	System maintenance item settings. Restart: Restart the inverter. Stop: Stop the inverter's AC output. Startup: Enable the inverter's AC output.
Multi-INV Role	In a master-slave parallel system, the inverter settings are as follows: Master: The master inverter in the system. Slave: The slave inverter in the system. Independent: Operates as an independent inverter.
*Multi-INV No	This menu is displayed only when the inverter is Master.Set the number of master-slave parallel. Range:1~10.
**Multi-INV Addr	This menu is displayed only when the inverter is Slave.Set the address of slave inverter. Range:1~9.The address will be "Auto" when "Multi-INV NO." is "1".
SOC Reset	SOC reset function. If turned it on, the battery will be automatically charged to calibrate the battery SOC. After the battery is charged, this function will be turned off automatically.
MPPT Parallel	MPPT parallel function switch. OFF: Disable this function.
MaxOutputSet	Select the maximum AC output power. Rated: Max.output power= Rated output power. Overload: Max. output power= 1.1 times Rated output power. Underload: Max. output power < Rated output power.
Export Ctrl	In the power export limit on mode, when the communication between the inverter and meter or the inverter and datalogger is interrupted, select the inverter operation mode from one of the follows, Hard, inverter stops AC output. Soft, inverter generates power as the "Feed in Grid" value set on the screen.
N-PE Check	The N and PE shorting function on the Back-up side in the off-grid operation status.

Item	Description
Shadow Scan	MPPT Shadow Scan Function Switch.
DI Ctrl	Select the control mode for the digital input signal, OFF: Disable. DRM: Demand Response Modes (for Australia and New Zealand). RCR: Ripple Control Receiver (for Germany and some other European countries).
Emergency Stop	Inverter Emergency Stop communication terminal status: OFF: Disabled. NO: Normally Open. The emergency stop switch is normally open; when the switch is closed, the inverter stop AC output. NC: Normally Closed. The emergency stop switch is normally closed; when the switch is opened, the inverter stop AC output.
CommsWatchDog	In a master-slave parallel system, when the function is turned on, the inverter stops working when communication with the master is lost.
BMS_ISO	Battery insulation detection switch.
Password Set	Password setup.

Customize Set

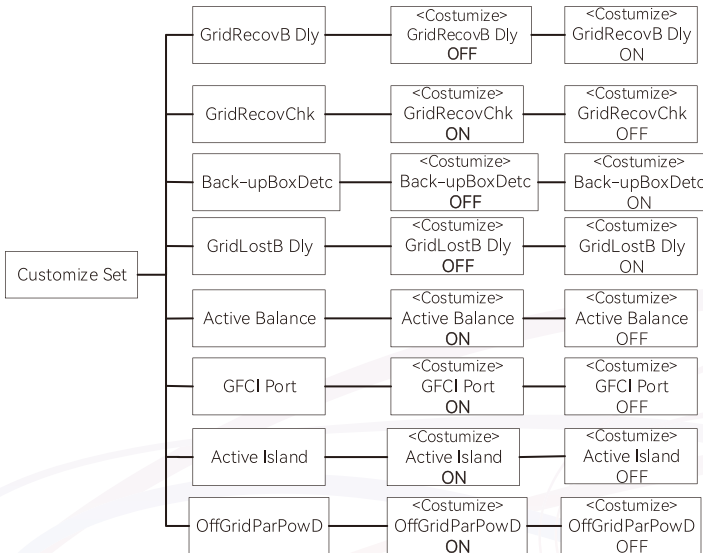

Item	Full name	Description	Application scenarios
GridRecovB Dly	Grid recover back-up output delay function	When the inverter is switched from the off-grid state to the grid-connected state, the back-up side selects normal output or delayed output. OFF(default): Normal output (within 10ms) ON: Delay output (delay 500ms)	When the customer connects to an ATS that cannot self-recover between grid side and back-up side, the customer selects the delay mode and the output is delayed by 500 ms on back-up side, so that the ATS can be switched from back-up side to grid side.
GridRecov Chk	Grid recover self-check function	The inverter is self-test when it is switched from the off-grid state to the grid-connected state. ON(default):Self-test OFF:No self-test Notice:If turn this function off, it may not meet local grid connection regulations	In areas where utility grid is unstable, if utility grid is cut off again during the self-test process, the output on the back-up side will be interrupted.
Back-upBoxDetc	Back-up box detection function	Turn on this function, and the inverter will detect whether the backup box is operating normally OFF(default):Not detected ON:Perform tests Notice:In off-grid parallel system, this function is enabled by default	The function is automatically turned on in off-grid paralleled system. When backup box connected with single inverter, please manually turn on this function.
GridLostB Dly	Grid lost back-up output delay function	When inverter is switched from Grid-connected state and off-grid state, the back-up side is normal output or delayed output. OFF(default): Normal output ON: Delay output	When the system is connected to the shock load, the inverter may not be switched and work normally when grid-connection state switched to off-grid state.and turning on the function can improve the probability of system restart.
GridLostB Dly	Grid lost back-up output delay function	When inverter is switched from Grid-connected state and off-grid state, the back-up side is normal output or delayed output. OFF(default): Normal output ON: Delay output	When the system is connected to the shock load, the inverter may not be switched and work normally when grid-connection state switched to off-grid state.and turning on the function can improve the probability of system restart.
Active Balance	Grid active balancing function	When there is no PV and no battery, whether the machine actively turns on the three-phase unbalance function to balance the power of the grid port. ON(default):turn on this function OFF:turn off this function	Turn the function on or off according to the grid requirements and needs

Item	Full name	Description	Application scenarios
GFCI Prot	GFCI protection function	The leakage current protection function is turned on or off. ON(default):turn on this protection OFF:turn off this protection	When there is abnormal leakage current in the system, which causes the system to fail to operate normally, the function can be disabled. Notice: Before disabling this function, need to confirm that there are no security risks.
Active Island	Active islanding disturbance function	Active islanding disturbance function is turned on or off. ON(default):turn on this function OFF:turn off this function Notice:Active islanding disturbance function is turned off, and the passive islanding protection function is still available.	In some test scenarios, need to disable this function, but no operation is required for normal condition .
OffGrid ParPowD	Off-grid parallel power distribution function	When multiple inverters are off-grid paralleled, the master schedules and distributes the power of the slaves. ON(default):turn on this function OFF:turn off this function Active islanding disturbance function is turned on or off. ON(default):turn on this function OFF:turn off this function Notice:Active islanding disturbance function is turned off, and the passive islanding protection function is still available.	If the off-grid side of the parallel power station is together, the function needs to be turned on; If the off-grid side of the parallel power station is not combined, the function needs to be turned off Under normal circumstances, the switch does not need to be operated, only the project is connected to the grid, and the standby side needs to be turned off when the load is connected independently.

View Test Records for Auto Test:

Select the relevant test items, and after waiting for a period, the test records will be displayed.

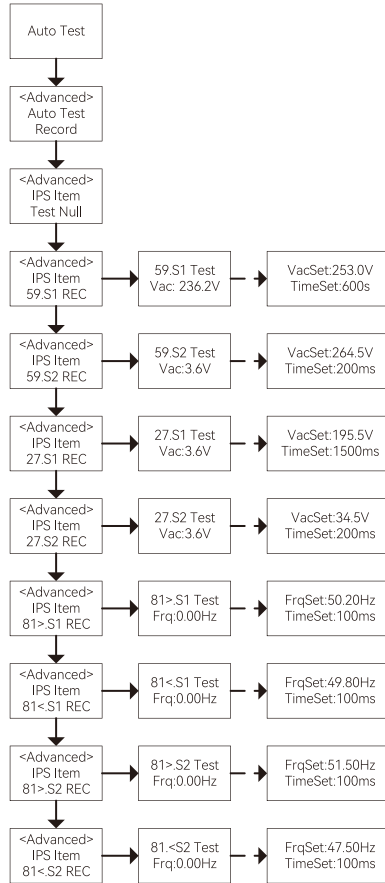

8.6 Reactive Power

The inverter provides a reactive power regulation function.

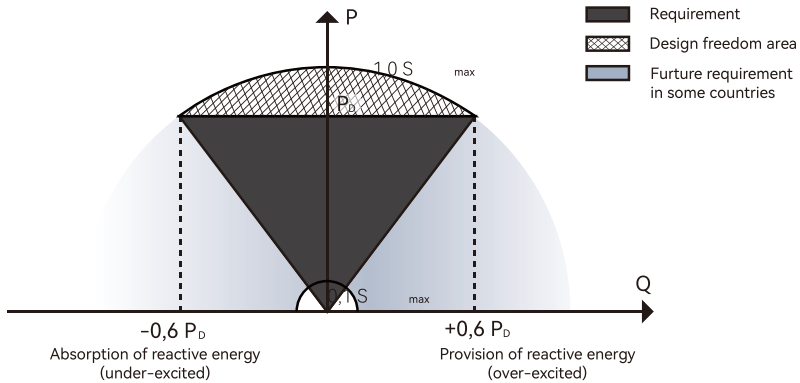

This mode can be enabled via configuration software. It is enabled by default in some regions, such as AU, DE market. For information on how to change default setpoints please contact Solinteg service team.

Descriptions of reactive power regulation mode:

Mode	Descriptions
Off	The PF is fixed at +1.000.
PF	The reactive power can be regulated by the parameter PF (Power Factor).
Qt	The reactive power can be regulated by the parameter fixed Q (in Pn%).
$\cos\varphi$ (P)	The PF changes with the output power of the inverter.
Q (U)	The reactive power changes with the grid voltage.

▼ 8.6.1 "Off" Mode

The reactive power regulation function is disabled. The PF is limited to +1.000.

▼ 8.6.2 "PF" Mode

The power factor is fixed and reactive power setpoint is calculated according to the current power.

The PF ranges from 0.8 leading to 0.8 lagging.

Leading: the inverter is sourcing reactive power to the grid.

Lagging: the inverter is injecting reactive power into the grid.

▼ 8.6.3 "Qt" Mode

In the Qt mode, system reactive power is fixed, and the system injects reactive power based on the proportion set by Fixed Q (in Pn%).

The setting range of the reactive power ratio is -60%~60%, corresponding to the ranges of inductive and capacitive reactive power regulation respectively.

▼ 8.6.4 "Cosφ(P)" Mode

The PF of the inverter output varies in response to the output power of the inverter.

"Cosφ(P)" mode parameter descriptions:

Parameter	Explanation	Range
Cosφ(P)_P1(Point A)	Output power at P1 on the Cosφ(P) mode curve (in percentage)	10%~100%
Cosφ(P)_P2(Point B)	Output power at P2 on the Cosφ(P) mode curve (in percentage)	20%~100%
Cosφ(P)_P3(Point C)	Output power at P3 on the Cosφ(P) mode curve (in percentage)	20%~100%
Cosφ(P)_K1(Point A)	Power factor at P1 on the Cosφ(P) mode curve	0.8~1
Cosφ(P)_K2(Point B)	Power factor at P2 on the Cosφ(P) mode curve	
Cosφ(P)_K3(Point C)	Power factor at P3 on the Cosφ(P) mode curve	
Cosφ(P)_Enter-Voltage	Voltage percentage for Cosφ(P) function activation	100%~110%
Cosφ(P)_Exit-Voltage	Voltage percentage for Cosφ(P) function deactivation	90%~100%

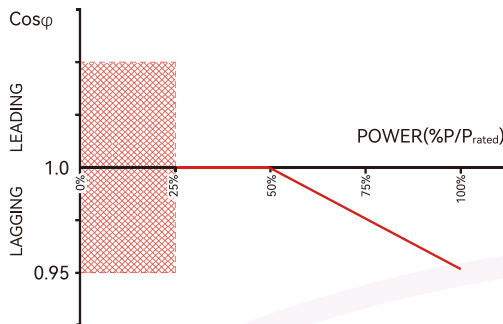

Cosφ(P) Curve

▼ 8.6.5 "Q(U)" Mode

The reactive power output of the inverter will vary in response to the grid voltage.

"Q(U)" mode parameter descriptions:

Parameter	Explanation	Range
QU_V1	Grid voltage limit at P1 on the Q(U) mode curve	80%~100%
QU_Q1	Value of Q/Sn at P1 on the Q (U) mode curve	0~60%
QU_V2	Grid voltage limit at P2 on the Q(U) mode curve	80%~100%
QU_Q2	Value of Q/Sn at P2 on the Q (U) mode curve	-60%~60%
QU_V3	Grid voltage limit at P3 on the Q(U) mode curve	100%~120%
QU_Q3	Value of Q/Sn at P3 on the Q (U) mode curve	-60%~60%
QU_V4	Grid voltage limit at P4 on the Q(U) mode curve	100%~120%
QU_Q4	Value of Q/Sn at P4 on the Q(U) mode curve	0~-60%
QU_Enter-Power	Active power for Q(U) function activation	20%~100%
QU_Exit-Power	Active power for Q(U) function deactivation	1%~20%

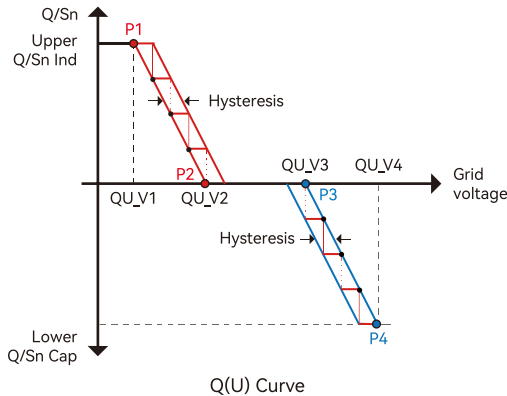

8.7 Active Power

The active power output of the inverter varies in response to the grid voltage.

It is enabled by default in some regions, such as AU, EU market. "P(U)" Mode is named "[b] Volt-watt mode" in AS/NZS 4777.2 Chapter 3.3 "Power quality response mode".

"P(U)" mode parameter descriptions:

Parameter	Explanation	Range
PU_V1	Grid voltage limit at P1 on the P(U) mode curve	100%~120%
PU_P1	Value of P/Sn at P1 on the P (U) mode curve	0~100%
PU_V2	Grid voltage limit at P2 on the P(U) mode curve	100%~120%
PU_P2	Value of P/Sn at P2 on the P (U) mode curve	0~100%
PU(τ)	Time constant of the P(U) mode curve	0~60s

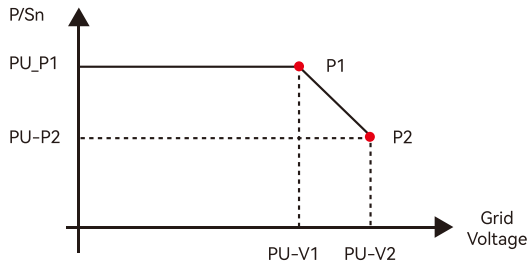

8.8 Check Firmware Version

The flow chart how to check firmware version on OLED display is following:

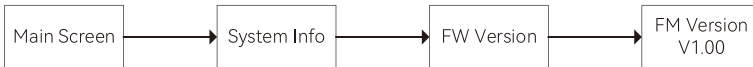

8.9 Grid Parameter

The inverter can check and adjust grid code, reactive and active modes setpoints via monitoring platform.

The following pictures illustrate how to check and adjust on the monitoring platform is following:

- ① On the monitoring interface, click "Device list" in the "Devices". Click "Configure" in "Operate" in the column of the device set.

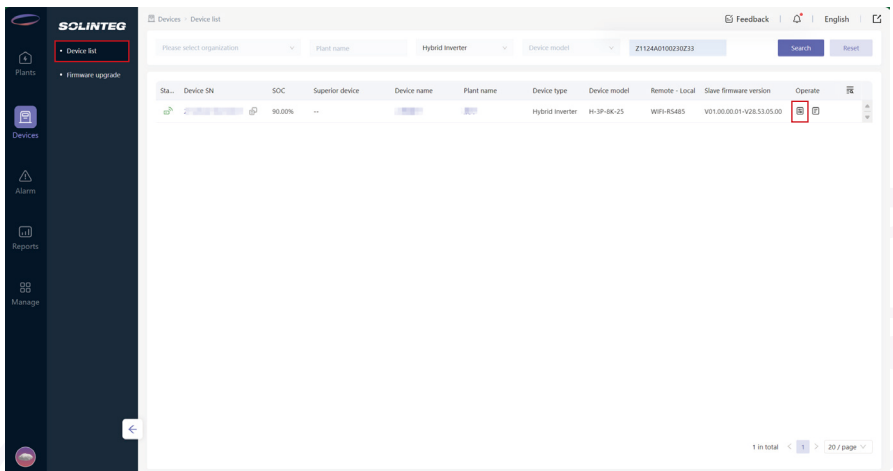

② Enter "Basic parameters" menu and check "Safety code settings" (Grid Code).

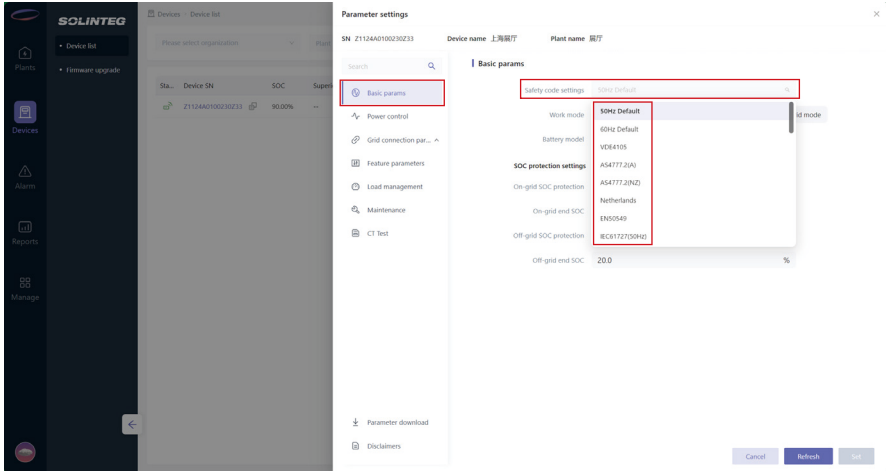

③ Enter "Protection Parameters" and "Grid Connection Parameter" menu under "Grid Connection Parameter" and check grid protection settings setpoints.

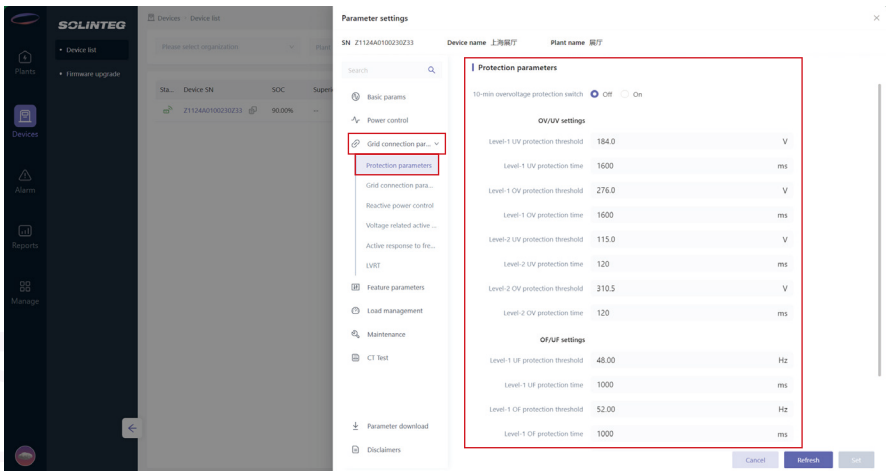

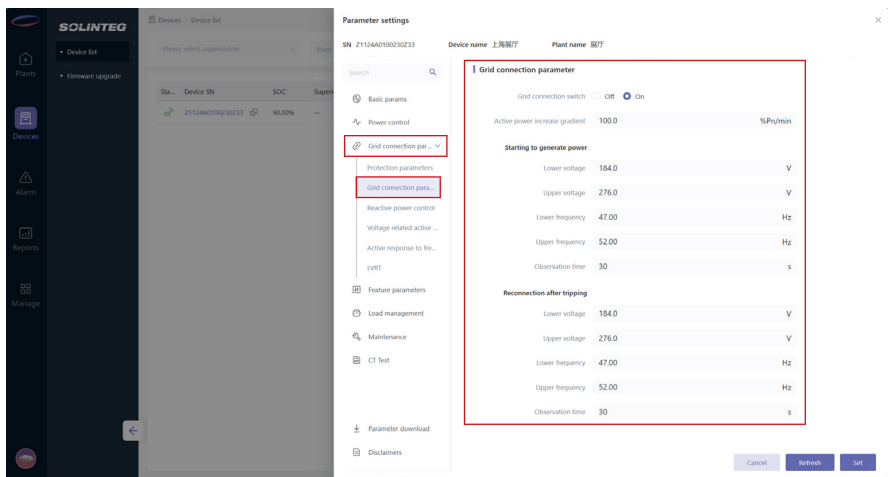

④ Enter "Reactive mode" menu under "Reactive power control" menu and check reactive mode setpoints.

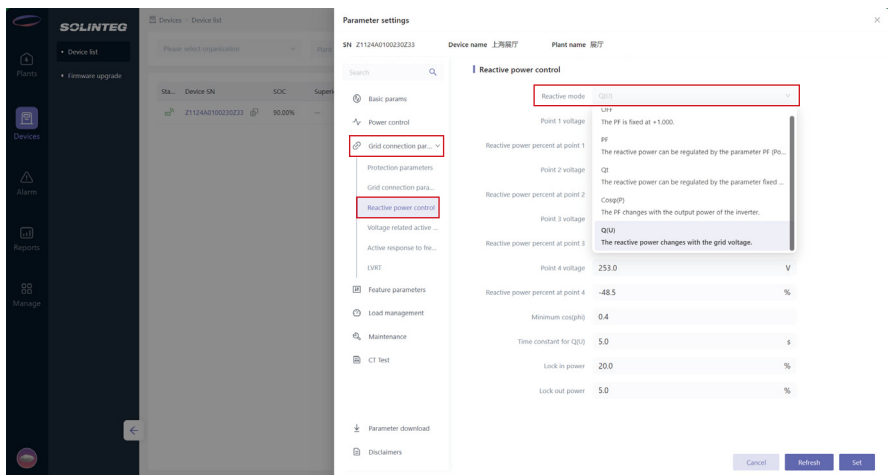

⑤ Enter "Voltage related active power P(U)" menu and check active mode setpoints.

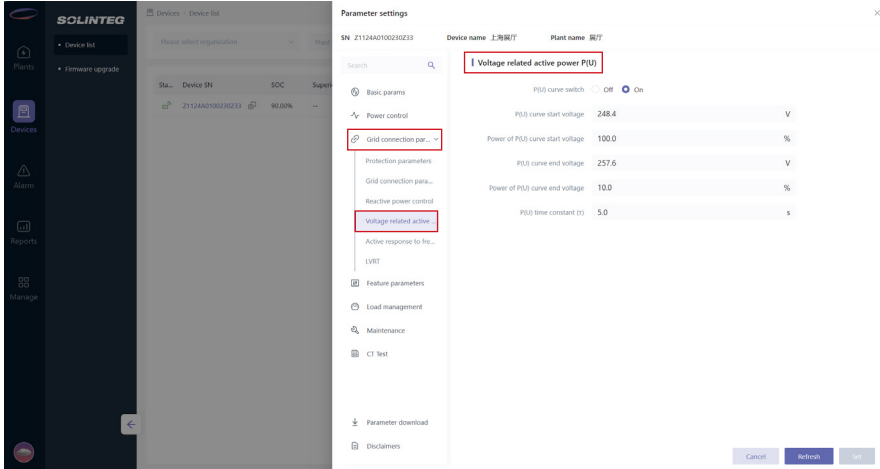

⑥ Once the installers or operators have finished modifying the relevant parameters, they need to enter a password after clicking "Set". Please reach out to Solinteg or the installer for the password.

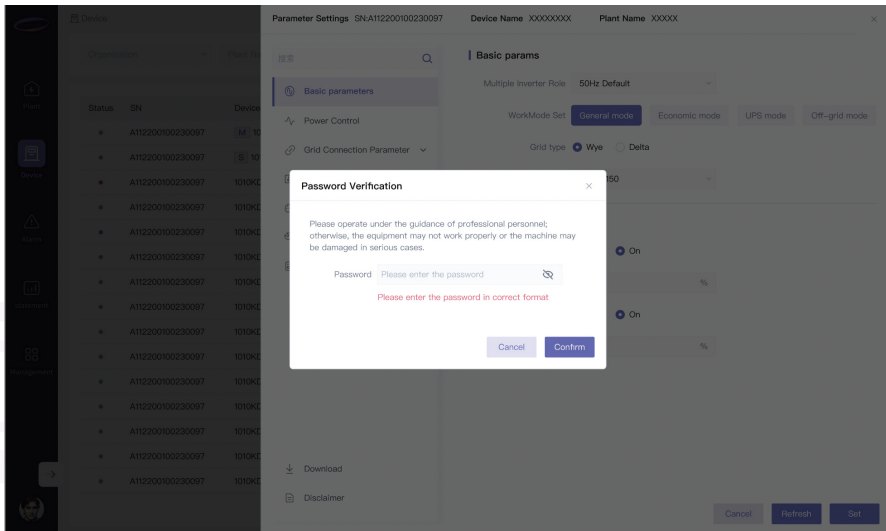



Please enter the password to adjust Grid Code, Protection Parameters setpoints, Grid Connection Parameter setpoints, Reactive Modes and Active Modes setpoints. To obtain the password, please contact Solinteg. Once the Grid Code and setpoints have been set at commissioning, these settings will be locked and cannot be edited unless a password is entered.

8.10 DI Ctrl

▼ 8.10.1 DRED

DRED function needs to be enabled via the OLED display.
Then set "DI Ctrl" to "DRM".

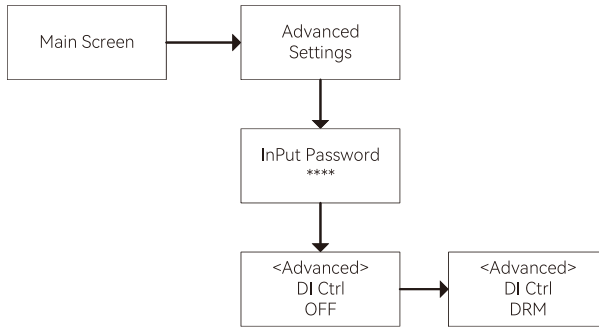

▼ 8.10.2 RCR

RCR function needs to be enabled via the OLED display.
Then set "DI Ctrl" to "RCR".

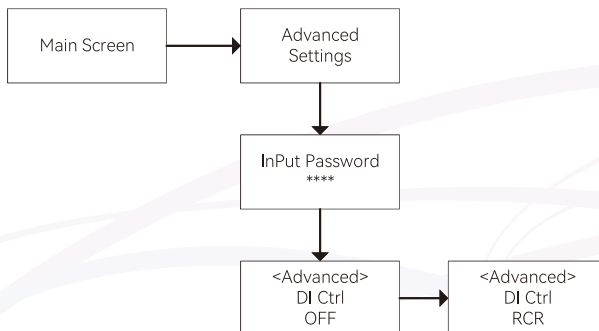

9 Monitoring

Solinteg M2HT-25~50K series inverter requires the connection of a communication module. Once the communication module is configured, the monitoring platform and the APP can achieve real-time monitoring of the inverter.

9.1 Communication Module

The M2HT-25-50K series inverter supports the connection of R2MD communication module. For instructions on using the R2MD, please refer to the [Quick Installation Guide].

9.2 Cloud Monitoring

IntegHub APP

Solinteg inverter provides a monitoring port that can collect and transmit data from the inverter to Solinteg monitoring platform via an external communication module.

IntegHub APP also includes a local Bluetooth configuration function.



Integhub Download QR Code

If download issues exist, contact your dealer or Solinteg service team.

Cloud monitoring web link: <https://portal.solinteg-cloud.com>

10 Troubleshooting

Solinteg M2HT-25~50K series hybrid inverter is designed in accordance with grid operation standards, and conform to the requirements of safety and EMC. The inverter had passed a series of rigorous tests to ensure it runs sustainably and reliably before shipment.

10.1 Status Code in Waiting

Code	Description
S01	WorkMode Not Set
S02	Emergency Stop Enable
S03	DC Conditions Unsatisfied
S04	Grid Voltage And Frequency Out Of Allowable Range
S05	Off-grid Switch Not Enabled In Off-grid
S06	No battery In Off-grid
S07	Operation Stopped By Command
S08	SOC Low And PV No Input
S09	Comm. interruption of the slave unit in parallel connection.
S10	Meter comm. interruption under Hard control of export limit.
S11	Waiting for Bypass State
S12	Updating Non-Power-Down Standby State
S13	Diesel Generator Fault
S15	Off-grid Status
S16	Updating Non-Power-Down Flag Clearing
S17	Command Power Limit
S18	Over Frequency Power Limit
S19	Over Temperature Power Limit
S20	Over Current Power Limit
S21	Reactive Power Limit
S22	Feed in Grid Power Limit
S23	Slow Loading

S24	Overvoltage Power Limit
S25	System Power Limit
S26	EMS Command Limitation
S32	PV Power Limited

10.2 Error Message and Solution

When a fault occurs, the corresponding error message will be shown on the OLED display, and in this case, the inverter might stop feeding into grid. The fault messages and their corresponding troubleshooting methods are listed below:

Error Message	Description	Solution
DC BUS Over Voltage	DC Bus voltage exceeds the upper limit.	1.Check whether the DC input voltage exceeds the limit. 2.Restart the inverter. 3.Seek help from the installer or manufacturer.
AC Current Sensor Fault	Current sensor detection circuit abnormal.	1.Restart the inverter. 2.Seek help from the installer or manufacturer.
E2 Fault	EEPROM chip damaged.	1.Restart the inverter. 2.Seek help from the installer or manufacturer.
PV Power Low	1.PV energy is insufficient. 2.Battery output capacity limited.	1.Check PV cable wiring. 2.Check battery status.
PV Over Voltage	PV input voltage exceeds the upper limit.	Reduce the number of PV panels to make sure that the open-circuit voltage of each string is lower than the inverter maximum allowed input voltage.
Relay Fault	Relay damaged.	1.Restart the inverter. 2.Seek help from the installer or manufacturer.
SCI Fault	Communication interruption between DSP and ARM.	1.Restart the inverter. 2.Seek help from the installer or manufacturer.
SPI Fault	DSP communication interruption.	1.Restart the inverter. 2.Seek help from the installer or manufacturer.
BAK Voltage Fault	1.Abnormal voltage input on the backup side. 2.Backup side internal relay damaged.	1.Check if the backup side is connected to the power supply. 2.Restart the inverter.
Backup Load Fault	Backup side load exceeds carrying capacity.	1.Reduce the load on the backup side. 2.Check the battery's load-carrying capacity.

Error Message	Description	Solution
Comm. Sampling Fault	AD port sampling interruption.	<ol style="list-style-type: none"> 1.Restart the inverter. 2.Seek help from the installer or manufacturer.
BAT Voltage Fault	Battery voltage exceeds the upper limit.	<ol style="list-style-type: none"> 1.Check if the DC input voltage is out of range. 2.Check if the battery shuts down when the fault occurs.
BAT Power Low	Abnormal status from battery BMS.	Check battery status.
BAT Invalid	<ol style="list-style-type: none"> 1.No battery connected. 2.Battery BMS abnormal. 	Check battery BMS status.
Grid Voltage Fault	Inverter detects that the grid voltage exceeds the limit of selected safety set range.	<ol style="list-style-type: none"> 1.Check whether the safety code is correct. 2.Check whether the AC cable wiring is correct. 3.Check whether the voltage increased cause by large AC cable impedance. In this case we could replce with a thicker AC cable. 4.Extend the voltage protection limit with the permission of the Electricity Authority.
Mains Lost	<ol style="list-style-type: none"> 1.Grid power outage. 2.AC switch or circuit is disconnected. 	<ol style="list-style-type: none"> 1.Check whether the mains supply is lost. 2.Check whether the AC cable wiring is correct.
Grid Frequency Fault	Inverter detects that the AC frequency exceeds the limit of selected safety set range. If occasional grid fluctuations lead to the fault, the inverter will recover automatically.	<ol style="list-style-type: none"> 1.Check whether the safety code is correct. 2.Extend the voltage protection limit with the permission of the Electricity Authority.
ISO Over Limitation	Inverter detects that DC side's insulation impedance to the ground is too low.	<ol style="list-style-type: none"> 1.Check whether PV panels, cables, and connectors are waterlogged or damaged. 2.Use a megger to measure ground resistance on the DC sidel, and the measured value should not be less than 500 KΩ. 3.Seek help from the installer or manufacturer.

Error Message	Description	Solution
N-PE Check Fault	The ground cable is loose or in poor connection on back-up side.	<ol style="list-style-type: none"> 1. Check whether the ground cable wiring is correct. 2. If grounding is unnecessary, N-PE check function can be disabled.
GFCI Fault	The inverter detects that the ground leakage current exceeds the limitation.	<ol style="list-style-type: none"> 1. Restart the inverter. 2. Check whether the PV panels, cables, and connectors are waterlogged or damaged. 3. Seek help from the installer or manufacturer.
GFCI Sensor Fault	GFCI sensor fault.	<ol style="list-style-type: none"> 1. Restart the inverter. 2. Seek help from the installer or manufacturer.
Inverter Over Current	Abnormal load on the backup side during off-grid operation.	<ol style="list-style-type: none"> 1. Check whether there is an impact load on the back-up side and whether the load power is too high. 2. Check whether back-up side is short circuit.
Internal Fan Fault	The external fan is broken, the power supply is insufficient, or the air channel is blocked.	<ol style="list-style-type: none"> 1. Restart the inverter. 2. Seek help from the installer or manufacturer.
Inverter Over Voltage	<ol style="list-style-type: none"> 1. During off-grid operation, backup side voltage exceeds the safety regulations. 2. Internal circuit abnormality. 	<ol style="list-style-type: none"> 1. Check whether there is an impact load on the back-up side and whether the load power is too high. 2. Check whether back-up side is short circuit.
Over Temperature	The inverter detects its high internal temperature.	<ol style="list-style-type: none"> 1. Check whether the inverter installation location is well ventilated. 2. Try to turn it off for a while, and then power it back on when it cools down. 3. Seek help from the installer or manufacturer.
Phase Lock Fault	<ol style="list-style-type: none"> 1. Abnormal grid voltage phase sequence. 2. Voltage sampling abnormality. 	<ol style="list-style-type: none"> 1. Check whether the AC cable wiring is correct. 2. Seek help from the installer or manufacturer.
HW Fault	Unknown hardware fault.	<ol style="list-style-type: none"> 1. Restart the inverter. 2. Seek help from the installer or manufacturer.

Error Message	Description	Solution
External Fan Fault	The internal fan is broken, the power supply is insufficient.	Check whether the fan is blocked by foreign matters, clean them if necessary.
DC BUS Over Voltage	DC Bus voltage exceeds the upper limit.	<ol style="list-style-type: none"> 1.Check whether the DC input voltage exceeds the limit. 2.Restart the inverter. 3.Seek help from the installer or manufacturer.
DCI Fault	Inverter detects that the the direct current injection value exceeds the range.	<ol style="list-style-type: none"> 1.Restart the inverter. 2.Seek for help from the installer or manufacturer.
DC BUS Voltage Unbalance	<ol style="list-style-type: none"> 1.Inverter current oscillation causing bus output power imbalance. 2.IGBT damaged. 	<ol style="list-style-type: none"> 1.Restart the inverter. 2.Seek help from the installer or manufacturer.
DC BUS Voltage Low	Backup side load exceeds carrying capacity.	<ol style="list-style-type: none"> 1.Reduce the load on the backup side. 2.Check the battery's load-carrying capacity.
SCI Fault	Internal communication got failed. Caused by a strong external magnetic field etc.	<ol style="list-style-type: none"> 1.Restart the inverter. 2.Seek help from the installer or manufacturer.
FLASH Fault	Internal storage got abnormal. Caused by a strong external magnetic field etc.	<ol style="list-style-type: none"> 1.Restart the inverter. 2.Seek help from the installer or manufacturer.
Meter Comm Fault	Abnormal communication between meter and inverter.	<ol style="list-style-type: none"> 1.Check whether the communication connection between inverter and meter is reliable. 2.Confirm whether the meter model is compatible.
BMS Comm Fault	Abnormal communication between inverter and battery BMS.	<ol style="list-style-type: none"> 1.Check whether the battery ID selection is correct. 2.Check whether the communication connection between inverter and BMS is reliable. 3.Check the working status of battery.

11 Operation and Maintenance

11.1 Inverter Maintenance



Incorrect operation do cause the risk of inverter damage or personal injury.

Please strictly follow the steps below.

- ① Select "stop" option on inverter screen or monitoring app to shut down inverter.
- ② Turn off all AC breaker.
- ③ Turn off inverter DC switch.
- ④ Turn off the battery switch, and disconnect the DC breaker on the battery side (if any).
- ⑤ Wait for 10 minutes to ensure the energy of capacitor is fully dissipated.
- ⑥ Confirm all the indicator lights are off.



Keep unprofessional person away.

A temporary alarm sign or barrier must be posted to keep unprofessional person away while performing electrical connection and maintenance.



When the inverter has an alarm or in some special cases, the inverter will work in the by pass status. In the by pass status, the grid will supply power to the load. At this time, it is not allowed to maintain the DC side of the inverter, if you want to maintain the DC side, you must stop the power and disconnect the DC switch before maintenance.



Any arbitrary replacement of internal components is forbidden. Please seek help from Solinteg for maintenance support. Otherwise, Solinteg will not take any responsibility.



Please remember not to do the self-maintenance before being familiar with the proper instruction of the whole process.

Routine maintenance:

Items	Methods	Period
System clean	Check dust or foreign matter on the heat-sink, air inlet and outlet.	Once 6-12 months
Electrical connection	Check whether the cables are in good connection.	Once 6-12 months
Seal inspection	Check whether all the terminals and ports are properly sealed. Reseal the cable hole if it is aging or not sealed.	Once a year

11.2 Battery Maintenance

Installation and maintenance of batteries should be performed or supervised with professional knowledge about batteries.

Please contact your battery supplier for detailed installation and maintenance information.



Do not dispose battery in fire, or it may explode.
Do not dismantle or break the battery. The electrolyte inside would be harmful to your body.



The battery has risk of electrical shock, the following scenario should be noticed during the operation.

- ① Remove metal items from your body.
- ② Use insulated tools.
- ③ Remove metal items from battery.
- ④ Turn off the DC breaker of the battery before assembling or disassembling battery terminals.
- ⑤ There is a risk of electrical shock if battery is unexpectedly grounded. Remove the grounding cable to avoid the electrical shock.

11.3 Earth Fault Alarm

When the PV array occur earth fault, the inverter will report the following alarm information. The alarm system shall continue until the earth fault is corrected.

- ① The warning indicator shows red constantly, and the OLED display will display "ISO Over Limitation" or "GFCI Fault".
- ② The monitoring platform and APP will show warning messages. Users can set up to receive alarm information via E-Mail.



Please ensure the inverter is installed in a high traffic area where the visual alarm (warning indicator) will be noticed.

12 Common Questions

1. Is there any output from the Back-up if the battery is not connected?

Answer: The Back-up has output when the inverter is in on-grid status, and it has no output when the inverter is in off-grid status.

2. Can the hybrid inverter be used as an off-grid inverter?

Answer: Yes, it can be used as an off-grid inverter, provided that a battery is connected.

3. Can low-voltage batteries be connected to the hybrid inverter?

Answer: No, only high-voltage lithium (LiFePO₄) batteries that are compatible with Solinteg M2HT-25~50K-150 hybrid inverter can be connected.

4. Can 18A high current PV modules be connected to the hybrid inverter ?

Answer: Yes. The M2HT-25~50K-150 hybrid inverter supports 20A DC input for single PV string.

5. Does the inverter have an overload output capability?

Answer: Yes, it does.

① In on-grid status, the AC output overload can be set to "Overload" by adjusting the "MaxOutputSet" on the inverter screen or monitoring platform.

Overload: Maximum output power = 1.1 times the rated output power.

② In off-grid status, the backup AC side's peak output capacity is as follows:

Model	M2HT-25/29.9/30/40/50K-150
Back-up/Off-grid peak output apparent power	1.5 times of rated output power, 10s

13 Appendix

13.1 Technical Parameters

Model	M2HT-25K-150	M2HT-29.9K-150	M2HT-30K-150	M2HT-40K-150	M2HT-50K-150
PV Input					
Start-up voltage (V)	210	210	210	210	210
Max. PV input voltage (V)*	1000*	1000*	1000*	1000*	1000*
Rated PV input voltage (V)	620	620	620	620	620
Operating voltage range (V)*	200-950*	200-950*	200-950*	200-950*	200-950*
Rated power MPPT voltage range (V)	200-850	200-850	200-850	265-850	330-850
No. of MPP trackers	4	4	4	4	4
No. of PV inputs per MPPT	2	2	2	2	2
Max. PV input current (A)	40*4	40*4	40*4	40*4	40*4
Max. short-circuit current (A)	50*4	50*4	50*4	50*4	50*4
Backfeed current to the array (A)	0	0	0	0	0
Battery Side					
Battery type	Lithium Battery (with BMS)				
Battery communication mode	CAN	CAN	CAN	CAN	CAN
Battery voltage range (V)	150-840	150-840	150-840	150-840	150-840
Max. charging/discharge current (A)	150	150	150	150	150
Short circuit current rating for the Battery input (A)	350	350	350	350	350
Grid Side/On-grid					
Rated output power (kW)	25.0	29.9	30.0	40.0	50.0
Max. output power (kW)	25.0	29.9	30.0	40.0	50.0

Model	M2HT-25K-150	M2HT-29.9K-150	M2HT-30K-150	M2HT-40K-150	M2HT-50K-150
Rated output apparent power (kVA)	25.0	29.9	30.0	40.0	50.0
Max. output apparent power (kVA)	25.0	29.9	30.0	40.0	50.0
Rated output voltage (V)	3L/N/PE,220/380V; 230/400V				
Rated output frequency (Hz)	50/60				
Rated output current (A)	37.9/36.2	45.3/43.3	45.5/43.5	60.6/58	75.8/72.5
Max. output current (A)	37.9	45.3	45.5	60.6	75.8
Power factor	0.8 leading ...0.8 lagging				
Max. total harmonic distortion	<3% @Rated output power				
DCI	<0.5%In				
Max. charging power of battery (kW)	25.0	30.0	30.0	40.0	50.0
Max. input apparent power (kVA)**	50.0	60.0	60.0	80.0	80.0
Rated input voltage (V)	3L/N/PE,220/380V; 230/400V				
Rated input frequency (Hz)	50/60				
Max. input current (A)	75.8	90.9	90.9	121.2	121.2
Back-up Side/Off-grid					
Rated output power (kW)	25.0	29.9	30.0	40.0	50.0
Max. output power (kW)	25.0	29.9	30.0	40.0	50.0
Rated output apparent power (kVA)	25.0	29.9	30.0	40.0	50.0
Max. output apparent power (kVA)	25.0	29.9	30.0	40.0	50.0
Rated output current (A)	37.9/36.2	45.3/43.3	45.5/43.5	60.6/58	75.8/72.5
Max. output current (A)	37.9	45.3	45.5	60.6	75.8
On/Off-grid switching tim	<10ms	<10ms	<10ms	<10ms	<10ms
Rated output voltage (V)	3L/N/PE,220/380V; 230/400V				

Model	M2HT-25K-150	M2HT-29.9K-150	M2HT-30K-150	M2HT-40K-150	M2HT-50K-150
Rated output frequency (Hz)	50/60				
Peak output apparent power (kVA)	1.5 times of rated output power, 10s				
Voltage harmonic distortion	<3% @Linear load				
Generator Side					
Max. input apparent power (kVA)	25.0	29.9	30.0	40.0	50.0
Max. charging power of battery (kW)	25.0	29.9	30.0	40.0	50.0
Rated input voltage (V)	3L/N/PE,220/380V; 230/400V				
Rated input frequency (Hz)	50/60				
Max. input current (A)	37.9	45.3	45.5	60.6	75.8
Efficiency					
Max. efficiency	97.6%				
European efficiency	97.1%				
Protection					
DC reverse polarity protection	Integrated				
Battery input reverse connection protection	Integrated				
Insulation resistance protection	Integrated				
Surge protection	Integrated(DC Type II / AC Type II)				
Over-temperature protection	Integrated				
Residual current protection	Integrated				
Islanding protection	Integrated				
AC over-voltage protection	Integrated				
Overload protection	Integrated				

Model	M2HT-25K-150	M2HT-29.9K-150	M2HT-30K-150	M2HT-40K-150	M2HT-50K-150
AC short-circuit protection	Integrated				
General Data					
Over voltage category	II(PV+Battery), III(Mains)				
Dimensions (mm)	919*739*305(W*H*D)				
Weight (KG)	89KG	89KG	89KG	89KG	89KG
Ingress protection	IP66	IP66	IP66	IP66	IP66
Protective class	I	I	I	I	I
Standby self-consumption (W)	< 30	< 30	< 30	< 30	< 30
Inverter topology	Transformerless				
Operating temperature range (°C)	-30~60	-30~60	-30~60	-30~60	-30~60
Relative humidity (%)	0~100	0~100	0~100	0~100	0~100
Operating altitude (m)	3000				
Cooling	Smart fan	Smart fan	Smart fan	Smart fan	Smart fan
Noise level (dB)	< 65	< 65	< 65	< 65	< 65
Display	OLED & LED				
Communication	CAN, RS485				

*PV Max. Input voltage is 950v, otherwise inverter will be waiting.

*Max apparent power means the maximum power imported from the grid used to satisfy the backup loads and charge the battery.

13.2 Contact Information

Should you have any question about this product, please contact us.

We need the following information to provide you the best assistance:

- Model of the device
- Serial number of the device
- Date of the device
- Fault code/name
- Brief description of the problem

China (HQ)

Wuxi Solinteg Power Co., Ltd.

Address: Building 10, No. 52-2 Changjiang South Road, Xinwu District, Wuxi, China

Website: www.solinteg.com

Service Mail: service@solinteg.com

www

INTEGRATE SOLAR INTELLIGENTLY



www.solinteg.com



M11-00061-03